

Warranty, Service & Repair

To register your product with the manufacturer, go to the Flowline website for on-line registration. The website address is as follows:

www.flowline.com

On-line Warranty Registration can be found under Contact Flowline on the Navigation Bar along the side of the home page.

If for some reason your product must be returned for factory service, go to the Flowline website listed above. Online Factory Service can be found under Contact Flowline on the Navigation Bar along the side of the home page. Click on **Return Authorization** to begin the registration process. You will need the following information at the time of registration:

1. Part Number and full Serial Number from product
2. Name and telephone number of someone who can answer technical questions related to the product and its application.
3. Return Shipping Address
4. Brief Description of the Symptom
5. Brief Description of the Application

Once you have received a Material Return Authorization number, ship the product prepaid in its original packing to:

Flowline Factory Service
MRA _____
10500 Humbolt Street
Los Alamitos, CA 90720

To avoid delays in processing your repair, write the MRA on the shipping label. Please include the information about the malfunction with your product. This information enables our service technicians to process your repair order as quickly as possible.

FLOWLINE®

EchoSonic Two-Wire Ultrasonic Level Transmitter Model LU05/11/12/13 Owner's Manual



Version 3.2A

© 2007 FLOWLINE Inc.

All rights reserved.

Manual # LU900012 LU05-0907-M3_2

WARRANTY

Flowline warrants to the original purchaser of its products that such products will be free from defects in material and workmanship under normal use and service for a period which is equal to the shorter of one year from the date of purchase of such products or two years from the date of manufacture of such products.

This warranty covers only those components of the products which are non-moving and not subject to normal wear. Moreover, products which are modified or altered, and electrical cables which are cut to length during installation are not covered by this warranty.

Flowline's obligation under this warranty is solely and exclusively limited to the repair or replacement, at Flowline's option, of the products (or components thereof) which Flowline's examination proves to its satisfaction to be defective. FLOWLINE SHALL HAVE NO OBLIGATION FOR CONSEQUENTIAL DAMAGES TO PERSONAL OR REAL PROPERTY, OR FOR INJURY TO ANY PERSON.

This warranty does not apply to products which have been subject to electrical or chemical damage due to improper use, accident, negligence, abuse or misuse. Abuse shall be assumed when indicated by electrical damage to relays, reed switches or other components. The warranty does not apply to products which are damaged during shipment back to Flowline's factory or designated service center or are returned without the original casing on the products. Moreover, this warranty becomes immediately null and void if anyone other than service personnel authorized by Flowline attempts to repair the defective products.

Products which are thought to be defective must be shipped prepaid and insured to Flowline's factory or a designated service center (the identity and address of which will be provided upon request) within 30 days of the discovery of the defect. Such defective products must be accompanied by proof of the date of purchase.

Flowline further reserves the right to unilaterally waive this warranty and to dispose of any product returned to Flowline where:

- a. There is evidence of a potentially hazardous material present with product.
- b. The product has remained unclaimed at Flowline for longer than 30 days after dutifully requesting disposition of the product.

THERE ARE NO WARRANTIES WHICH EXTEND BEYOND THE DESCRIPTION ON THE FACE OF THIS WARRANTY. This warranty and the obligations and liabilities of Flowline under it are exclusive and instead of, and the original purchaser hereby waives, all other remedies, warranties, guarantees or liabilities, express or implied. EXCLUDED FROM THIS WARRANTY IS THE IMPLIED WARRANTY OF FITNESS OF THE PRODUCTS FOR A PARTICULAR PURPOSE OR USE AND THE IMPLIED WARRANTY OF MERCHANTABILITY OF THE PRODUCTS.

This warranty may not be extended, altered or varied except by a written instrument signed by a duly-authorized officer of Flowline, Inc.

Spec Tech Industrial 203 Vest Ave. Valley Park, MO 63088 Phone: 888 SPECTECH

E-mail: sales@spectechind.com

www.spectechind.com

SPECIFICATIONS

Step One

Range:	LU05: 2" to 4.0' (5 cm to 1.2 m) LU12: 4" to 9.8' (10 cm to 3m) LU11: 4" to 16.4' (10 cm to 5m) LU13: 8" to 26.2' (20 cm to 8m)
Accuracy:	LU05: 0.125" (3 mm) LU11/12/13: ± 0.2% of span in air
Resolution:	LU05/12: 0.019" (0.5 mm) LU11/13: 0.039" (1 mm)
Beam width:	LU05/12: 2" (5 cm) dia. LU11/13: 3" (7.6 cm) dia.
Dead band:	LU05: 2" (5 cm) LU11/12: 4" (10 cm) LU13: 8" (20 cm)
LED indication:	Power, calibration and diagnostics
Memory:	Non-volatile
Supply voltage:	12 to 28 VDC
Loop resist.:	500 Ohms @ 24 VDC
Signal output:	4-20 mA, two-wire
Signal invert:	4-20 mA or 20-4 mA
Calibration:	Target, calibration wire
Fail-safety:	Reverts to 22 mA
Process temp.:	F: -4° to 140° / C: -20° to 60°
Temp. comp.:	Automatic
Electronics temp.:	F: -40° to 160° / C: -40° to 71°
Pressure:	30 psi (2 bar) @ 25° C., derated @ 0.857 psi (.057 bar) per °C. above 25° C.
Enclosure rating:	NEMA 4X - encapsulated, corrosive resistance & submersible
Encl. material:	PC/ABS FR
Trans. material:	PVDF
Cable jacket mat.:	50_1: PP
Cable type:	50_1: 3-conductor, shielded
Cable length:	50_1: 10' (3m)
Conduit entrance:	51_1: Dual, 1/2" NPT
Process mount:	LU05/12: 1" NPT (1" G) LU11/13: NPT (2" G)
Mount. gasket:	Viton®
Classification:	General purpose
CE compliance:	EN 61326 EMC

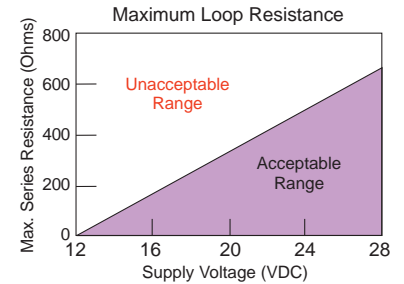
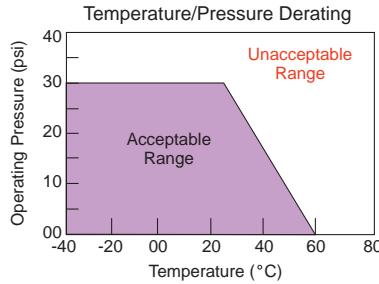

**LU_-50_1
Enclosure
Top View**

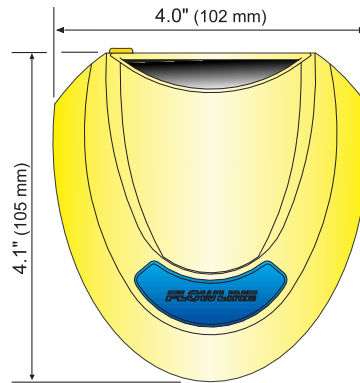

**LU_-51_1
Enclosure
Top View**

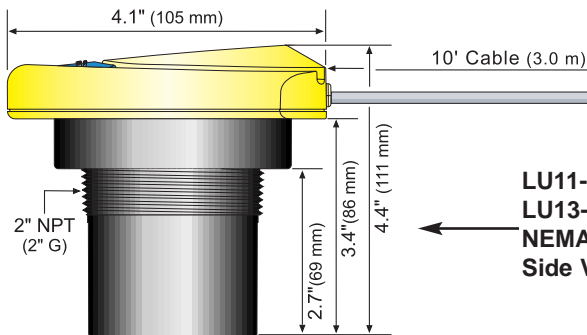
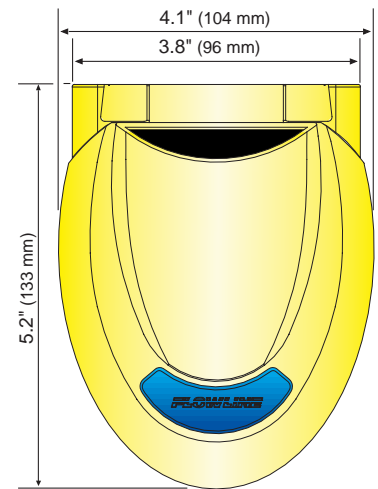

**LU11-50_1
LU13-50_1
NEMA 6
Side View**

**LU11-51_1
LU13-51_1
NEMA 4X
Side View**

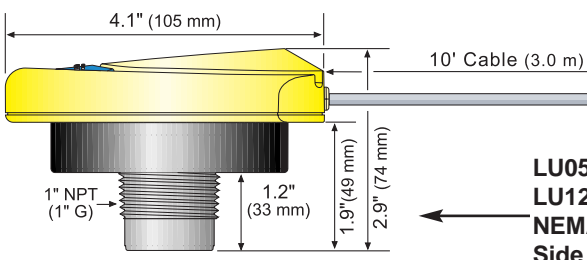
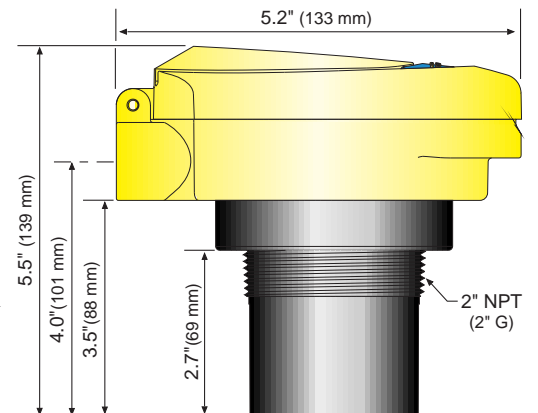

**LU05-50_1
LU12-50_1
NEMA 6
Side View**

**LU05-51_1
LU12-51_1
NEMA 4X
Side View**

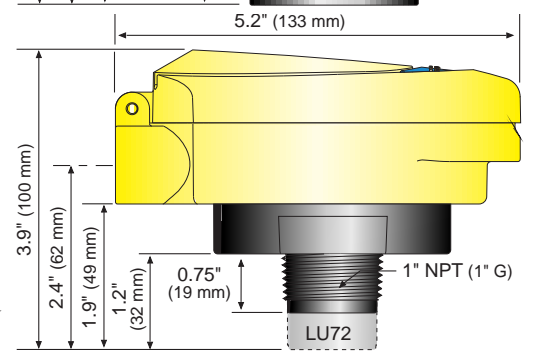

SAFETY

Step Two

⚠ About this Manual: PLEASE READ THE ENTIRE MANUAL PRIOR TO INSTALLING OR USING THIS PRODUCT. This manual includes information on the LU05-5__1, LU11-5__1, LU12-5__1 and LU13-5__1 Ultrasonic Level Transmitter from FLOWLINE. Please refer to the part number located on the transmitter label to verify the exact model configuration which you have purchased.

⚠ User's Responsibility for Safety: FLOWLINE manufactures a broad range of level sensing technologies. While each of these sensors is designed to operate in a wide variety of applications, it is the user's responsibility to select a sensor model that is appropriate for the application, install it properly, perform tests of the installed system, and maintain all components. The failure to do so could result in property damage or serious injury.

⚠ Proper Installation and Handling: Only properly trained staff should install and/or repair this product. Install the transmitter with the Viton gasket and never overtighten the transmitter within the fitting. Always check for leaks prior to system start-up.

⚠ Wiring and Electrical: A supply voltage of 12-28 VDC is used to power the transmitter. The sensor circuit should never exceed a maximum of 28 volts DC. Electrical wiring of the sensor should be performed in accordance with all applicable national, state, and local codes.

⚠ Material Compatibility: The LU__-5__1 enclosure is made of a flame retardant Polycarbonate (PC/ABS FR). The transducer is made of Polyvinylidene Fluoride (PVDF). Make sure that the model which you have selected is chemically compatible with the application media.

⚠ Enclosure: While the transmitter housing is liquid-resistant the LU__-5__1 is not designed to be operational when immersed. It should be mounted in such a way that the enclosure and transducer do not come into contact with the application media under normal operational conditions.

⚠ Make a Fail-Safe System: Design a fail-safe system that accommodates the possibility of transmitter and/or power failure. FLOWLINE recommends the use of redundant backup systems and alarms in addition to the primary system.

⚠ Flammable, Explosive or Hazardous Applications: The LU__-5__1 should not be used within classified hazardous environments.



Always use the Viton gasket when installing the LU1_-5__1 transmitter, and always connect the shield wire to the common ground.

OVERVIEW

Step Three

A. Application: The general purpose two-wire ultrasonic transmitter provides non-contact level measurement up to 26.2' or 8m, and is ideally suited for challenging corrosive, coating or waste liquids. The transmitter is broadly selected for atmospheric bulk storage, day tank, process vessel and waste sump applications. Media examples include polymer, ink and hydrochloric acid.

B. Part Number: The part and serial numbers are located on the wrench flat. Check the part number on the product label and confirm which of the below model configurations you have purchased:

Part Number	Range	Enclosure	Mount
LU05-5001	1.2m (4.0')	Cable Connection	1" NPT
LU05-5061	1.2m (4.0')	Cable Connection	1" G
LU05-5101	1.2m (4.0')	Conduit Connection	1" NPT
LU05-5161	1.2m (4.0')	Conduit Connection	1" G
LU12-5001	3m (9.8')	Cable Connection	1" NPT
LU12-5061	3m (9.8')	Cable Connection	1" G
LU12-5101	3m (9.8')	Conduit Connection	1" NPT
LU12-5161	3m (9.8')	Conduit Connection	1" G
LU11-5001	5m (16.4')	Cable Connection	2" NPT
LU11-5061	5m (16.4')	Cable Connection	2" G
LU11-5101	5m (16.4')	Conduit Connection	2" NPT
LU11-5161	5m (16.4')	Conduit Connection	2" G
LU13-5001	8m (26.2')	Cable Connection	2" NPT
LU13-5061	8m (26.2')	Cable Connection	2" G
LU13-5101	8m (26.2')	Conduit Connection	2" NPT
LU13-5161	8m (26.2')	Conduit Connection	2" G

C. Conduit Enclosure: The conduit enclosure (-51_1) has a flip cover with two 1/2" NPT female conduit ports and an internal terminal strip for wiring. To open the enclosure, you will need a small insertion tool such as a small screwdriver or paperclip. Insert the tool into the hole located at the front of the enclosure and gently push on the latching mechanism to release the cover. Rotate the hinged cover up for 135° access to the terminal strip. **Before closing the enclosure, make sure that the enclosure gasket is properly seated, and that any conduit fittings, cable connectors and/or plugs are installed correctly and sealed.**

LU__-51_1 Enclosure Shown

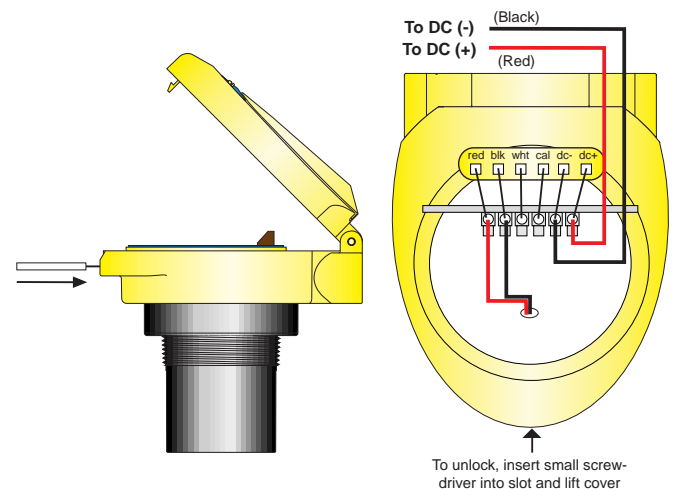

PREPARATION

Step Four

A. Supply Voltage: The transmitter power supply voltage should never exceed a maximum of 28 VDC. Flowline controllers and meters have built-in 24 VDC power supplies for use with the transmitter. Alternative controllers and/or power supplies with a minimum output may also be used with the transmitter for calibration and/or operation.

B. Cable Length: The cable length may be extended up to a maximum of 1000 feet between the transmitter and its point of termination, using a well-insulated, shielded wire from 14 to 18 gauge.

C. Wire Stripping: Models LU__-50_1 with cable connections are provided with a 10' cable. If necessary, use a 10 gauge wire stripper and carefully remove the outer layer of polypropylene insulation from the last 1-1/4" of the transmitters cable. Unwrap and discard the exposed foil shield from around the signal wires. With a 20 gauge wire stripper, remove the last 1/4" of the colored insulation from the signal wires.

D. Factory Span: Models LU05-5__1, LU11-5__1, LU12-5__1, LU13-5__1 are factory calibrated with 4 mA at their maximum range (tank empty) and 20 mA (tank full) at their minimum range values. The 4 and 20 mA span set points can be reverse calibrated on all models.

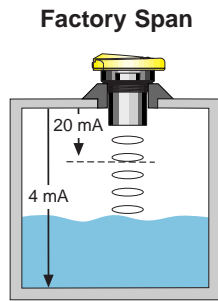

E. Maximum Applied Range: The Individual or cumulative effects of agitation, vapor or foam can reduce the overall quality of signal return and shorten the maximum applied range of the transmitter. To determine the maximum applied range of the transmitter in your application, refer to the below derating chart.

Maximum Applied Range Derating Chart

LU05/ 12-5__1

Agitation = 1-3 @ 100 kHz
 Vapor = 4-6 @ 100 kHz
 Foam = 5-6 @ 100 kHz

LU11/13-5__1

Agitation = 1-3 @ 50 kHz
 Vapor = 3-5 @ 50 kHz
 Foam = 4-6 @ 50 kHz

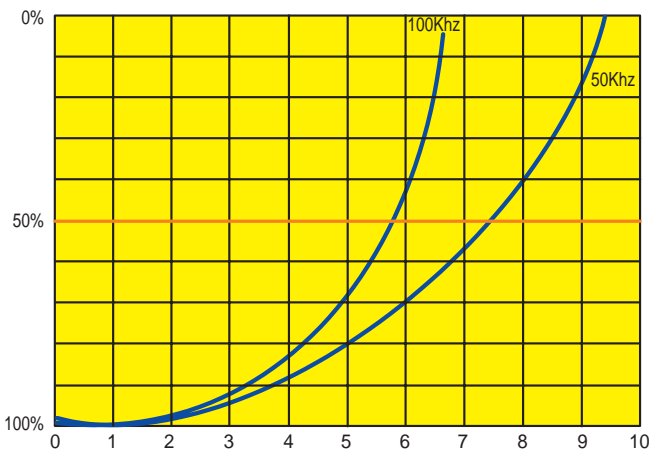

CALIBRATION

Step Five

A. Factory Settings: One option for calibration is to use the factory setting of the EchoSonic. Each version of EchoSonic has a preset 4mA and 20 mA as seen below:

Factory Set Points			
Transmitter	4 mA Setting	20 mA Setting	Span
LU05-5__1	4.0' (1.2m)	2" (5 cm)	46" (115 cm)
LU12-5__1	9.8' (3m)	4" (10 cm)	114" (290 cm)
LU11-5__1	16.4' (5m)	4" (10 cm)	193" (490 cm)
LU13-5__1	26.2' (8m)	8" (20 cm)	307" (790 cm)

Due to advances in the electronics with the Digital Infinity transmitters, any resolution improvements are negligible when decreasing the overall operational range of the transmitter.

Version	Resolution inches (cm)
LU05-5__1	0.019" (0.05 mm)
LU12-5__1	0.019" (0.05 mm)
LU11-5__1	0.039" (0.1 mm)
LU13-5__1	0.039" (0.1 mm)

Flowline recommends using the original factory settings with the transmitter and making the range adjustments in the local panel meter, display or PLC system.

B. Distance to Current Charts: Below are charts for each version of EchoSonic. The charts indicate the current at specific distances away from the transmitter. To located the current equivalent to an empty /full tank, follow the instructions below:

1. Measure the distance from the bottom of the sensor to the bottom of the tank.
2. Locate this value under distance column for the transmitter version.
3. Select the corresponding current value from the chart. Distances not listed can be extrapolated from the next highest and lowest distances.
4. Repeat the same steps for the full tank setting.

C. Display Adjustments: Typical panel meters and displays use a 2-point method for calibration, based upon empty and full settings. Each setting will have a current reading and a corresponding value that appears on the display at that current. For example, 4 mA = 0.0 and 20.0 mA = 100.0 is a common setting. This represents a display of 0 when 4mA is applied to the sensor and 100.0 when 20 mA is applied to the sensor.

The same can be accomplished using the factory setting of the EchoSonic. For example, a LU05-5__1 transmitter will output 8.2 mA when the level is 36" away form the transmitter (from chart). If the sensor is installed on a 36" tall tank, then the current output when the tank is empty will be 8.2 mA. When programming the display, entering 8.2 mA = 0.0 and 20.0 mA = 100.0 will have the display read between 0 to 100. This will have the resolution as calibrating the LU05-5__1 to 4mA = 36.0 and 20mA = 2.0 and the display programmed to 4mA = 0.0 and 20 mA = 100.0. This method avoids having to calibrate the sensor and will have no effect with respect to the resolution of the unit.

CALIBRATION

Step Six

D. Conversion Chart (Nominal) for LU05-5__1:

Distance inches	Current mA	Distance inches	Current mA	Distance inches	Current mA
02	20.0	20	13.7	40	6.8
04	19.3	24	12.3	44	5.4
08	17.9	28	11.0	48	4.0
12	16.5	32	09.6		
16	15.1	36	08.2		

Nominal Scaling Factor (2.875 inches/mA)

Distance cm	Current mA	Distance cm	Current mA	Distance cm	Current mA
05	20.0	50	13.7	100	06.8
10	19.3	60	12.3	110	05.4
20	17.9	70	11.0	120	04.0
30	16.5	80	09.6		
40	15.1	90	08.1		

Nominal Scaling Factor (7.188 cm/mA)

E. Conversion Chart (Nominal) for LU12-5__1:

Distance inches	Current mA	Distance inches	Current mA	Distance inches	Current mA
04	20.0	42	14.7	84	8.8
06	19.7	48	13.8	90	7.9
12	18.9	54	13.0	96	7.1
18	18.0	60	12.1	102	6.2
24	17.2	66	11.3	108	5.4
30	16.3	72	10.5	114	4.7
36	15.5	78	9.6	118	4.0

Nominal Scaling Factor (7.25 inches/mA)

Distance cm	Current mA	Distance cm	Current mA	Distance cm	Current mA
10	20.0	125	13.7	250	06.8
25	19.2	150	12.3	275	05.4
50	17.8	175	10.9	300	04.0
75	16.4	200	09.5		
100	15.0	225	08.1		

Nominal Scaling Factor (18.125 cm/mA)

CALIBRATION

Step Seven

F. Conversion Chart (Nominal) for LU11-5__1:

Distance inches	Current mA	Distance inches	Current mA	Distance inches	Current mA
04	20.0	72	14.4	144	8.4
12	19.3	84	13.4	156	7.4
24	18.3	96	12.4	168	6.4
36	17.3	108	11.4	180	5.4
48	16.4	120	10.4	192	4.4
60	15.4	132	9.4	197	4.0

Nominal Scaling Factor (12.062 inches/mA)

Distance cm	Current mA	Distance cm	Current mA	Distance cm	Current mA
10	20.0	175	14.6	350	08.9
25	19.5	200	13.8	375	08.1
50	18.7	225	13.0	400	07.3
75	17.9	250	12.2	425	06.4
100	17.1	275	11.3	450	05.6
125	16.2	300	10.5	475	04.8
150	15.4	325	09.7	500	04.0

Nominal Scaling Factor (30.625 cm/mA)

G. Conversion Chart (Nominal) for LU13-5__1:

Distance inches	Current mA	Distance inches	Current mA	Distance inches	Current mA
08	20.0	120	14.2	240	07.9
12	19.8	132	13.5	252	07.3
24	19.2	144	12.9	264	06.7
36	18.5	156	12.3	276	06.0
48	17.9	168	11.7	288	05.4
60	17.3	180	11.0	300	04.8
72	16.7	192	10.4	312	04.2
84	16.0	204	09.8	315	04.0
96	15.4	216	09.2		
108	14.8	228	08.5		

Nominal Scaling Factor (19.188 inches/mA)

Distance cm	Current mA	Distance cm	Current mA	Distance cm	Current mA
20	20.0	300	14.3	575	08.6
50	19.4	325	13.7	600	08.1
75	18.9	350	13.2	625	07.6
100	18.4	375	12.7	650	07.1
125	17.8	400	12.2	675	06.6
150	17.3	425	11.7	700	06.1
175	16.8	450	11.2	725	05.5
200	16.3	475	10.7	750	05.0
225	15.8	500	10.2	775	04.5
250	15.3	525	09.6	800	04.0
275	14.8	550	09.1		

Nominal Scaling Factor (48.75 cm/mA)

CALIBRATION

Step Eight

H. Target Calibration - Setting 4 mA or 20 mA: The second option for calibrating the EchoSonic is to change the 4mA from the factory setting to the empty tank and the 20 mA from the factory setting to the full tank. This method will require that the level of liquid be lowered to the empty level and raised to the full level. If this is not possible, the changes can be accomplished by pointing the transmitter at a wall or flat object the equivalent distances for empty and full. This method is referred to as Target Calibration.

I. Calibration Tools: To target calibrate the transmitters 4-20 mA span you will need a 12-28 VDC power supply, tape measurer, flat reflective target such as a wall, optional multimeter and Flowline box insert for use as a product holder.

J. Off Tank Target Calibration: Locate a flat reflective calibration target such as a wall. Place the transmitter perpendicular to the target in the provided Flowline box insert or equivalent holder. **Alternatively, you may hold the transmitter with your hand, but it is critical that the product is held steady and perpendicular to the target during span calibration.**

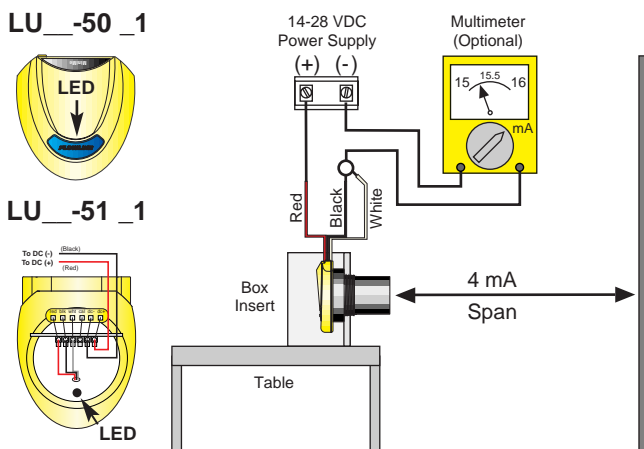

K. 4 mA Span Calibration Procedure (Tank Empty)

1. If the transmitter is wired with power ON, turn power OFF to the transmitter and wait 30 seconds before continuing.
2. Connect the the Red transmitter wire to the (+) terminal of the power supply. Connect the Black and White transmitter wires to the (-) terminal of the power supply.
3. Stretch the tape measurer out to the appropriate distance in between the transmitter and target.
4. Position the transmitter at the desired 4 mA calibration distance defined as the air gap space between the transducer and the target. **Make sure that the transmitter is stationary and perpendicular to the target before continuing.**
5. To calibrate the set point, turn power ON to the transmitter and wait for the LED to flash indicating that the set point has been accepted. Depending upon the span, this can take up to 45 seconds. If the LED does not flash within 60 seconds, check to make sure that line power is at least 14 VDC and that the transmitter and target are both stationary and perpendicular.
6. Turn power OFF to the transmitter and disconnect the White transmitter wire from (-) terminal of the power supply, leaving the Black transmitter wire attached.
7. Continue ahead to the 20 mA span calibration procedure.

CALIBRATION

Step Nine

L. 20 mA Span Calibration Procedure (Tank Full)

1. If the transmitter is wired with power ON, turn power OFF to the transmitter and wait 30 seconds before continuing.
2. Connect the the Black transmitter wire to the (-) terminal of the power supply. Connect the Red and White transmitter wires to the (+) terminal of the power supply.
3. Stretch the tape measurer out to the appropriate distance in between the transmitter and target.
4. Position the transmitter at the desired 20 mA calibration distance defined as the air gap space between the transducer and the target. **If the transmitter is installed in a flange fitting with riser, then the 20 mA calibration distance should be no less than the riser height + half the transmitter's dead band specification (ie: 4" riser + 8" dead band = 8" minimum 20 mA calibration distance). Make sure that the transmitter is stationary and perpendicular to the target before continuing.**
5. To calibrate the set point, turn power ON to the transmitter and wait for the LED to flash indicating that the set point has been accepted. Depending upon the span, this can take up to 10 seconds. If the LED does not flash within 30 seconds, check to make sure that line power is at least 12 VDC and that the transmitter and target are both stationary and perpendicular.
6. Turn power OFF to the transmitter and disconnect the White transmitter wire from (+) terminal of the power supply, leaving the Red transmitter wire attached.
7. The 4-20 mA span calibration is now complete.

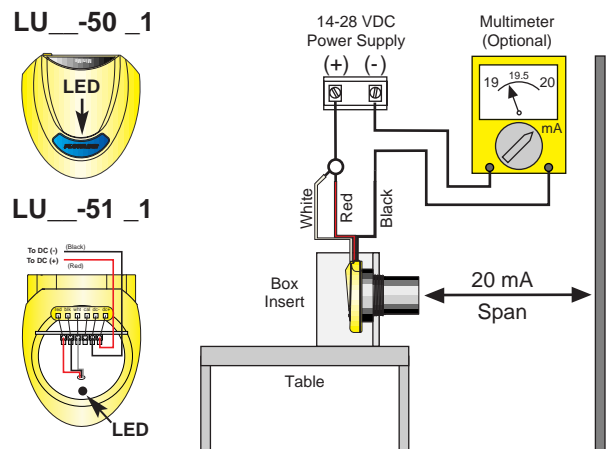

M. On Tank Target Calibration: Alternatively, the transmitter's 4-20 mA span may be target calibrated installed ON the tank by raising or lowering the liquid level to the desired 4 mA (tank empty) and 20 mA (tank full) span distances. To do so, follow the above steps #8-K and #9-M calibration procedure with the exception of moving the liquid level (versus the transmitter) in steps #8-K-4 and #9-M-4. **During calibration, make sure that the liquid is still and that there is at least some liquid in the tank for the 4 mA (tank empty) set point.**

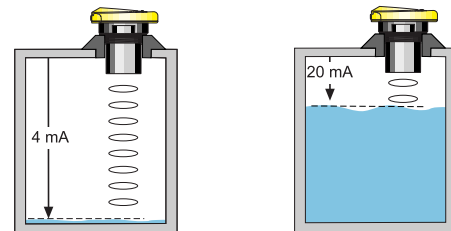

INSTALLATION

Step Ten

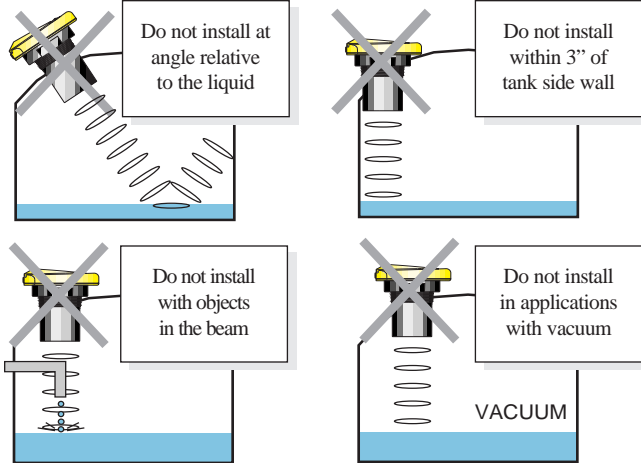

Warning

Flowline Ultrasonic transmitters have been optimized for use in non-metallic fittings. For best performance, avoid the use of metallic fittings.

Install the appropriate installation fitting. Make sure that the fitting and transmitter threads are not damaged or worn. Install the transmitter with the included Viton mounting gasket. Hand tighten the transmitter within the fitting. Perform an installed leak test under normal process conditions prior to system start up.

A. Fitting Selection: Check the transmitter part number to determine the required fitting mount size and thread type. The transmitter is commonly installed in tank adapters, flanges, brackets or stand pipes. *Note: Always include the gasket when installing the EchoSonic.*

Gasket

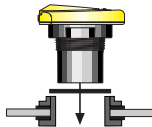

Tank Adapter



1. Tank Adapter: Select a tank adapter fitting with minimal height so as to ensure that the installed transducer will not be substantially elevated into the fitting such as the Hayward 2" Tank Adapter (socket by thread). For the LU05-5_1 and LU12-5_1 versions, add a Reducer Bushing such as the Spears 2" x 1", thread x thread, Reducer Bushing (series 839-249, Flowline p/n LM52-1001). Avoid tank adapter (thread x thread) styles and/or pipe stops forward of the installed transducer.

2" Tank Adapter Socket x Thread



Tank Adapter w/ 2"x1" Reducer Bushing



Tank Adapter Thread x Thread



INSTALLATION

Step Eleven

2. Riser: Installations with tall, narrow risers can impede the acoustic signal. Select a fitting with the right riser height versus inner diameter geometry.

Riser Specifications	Riser Specifications	
	Inner Diameter	Maximum Height
	2" (5 cm)	3" (7.6 cm)
	4" (10 cm)	8" (20 cm)
	6" (15 cm)	12" (30 cm)

3. Flange: If installing on a flange, select a flange with a thread that is above the plane of the flange, such as the Spears 2" One Piece Flange (series 852-020). Avoid the use of blind flanges with tapped threads or flanges where the threads are even with the plane of the flange, such as the Banjo 2" Poly ANSI Flange (series AF200).

2" Flange w/ thread out of plane



2" Flange w/ thread in plane



If the installation requires the use of a blind flange, tap a thread 1" larger than the sensors thread and add a Reducer Bushing such as a Spears thread x thread Reducer Bushing [series 839-338 (3"x2") for LU11 and LU13 versions or series 839-249 (2"x1") for LU05 and LU12 versions].

2" Flange w/ Reducer Bushing



4. Side Mount Bracket: The LM50-1001 side mount bracket or equivalent can be used for open tank top installations against the side wall. For the LU05 and LU12 versions, order the LM50-1001-1, which includes a 2" x 1" Reducer Bushing.

Side Mount Bracket

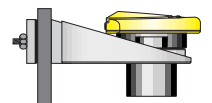

5. Stand Pipe: A stand pipe may be used to dampen turbulence.

Flowline recommends using a stand pipe when foam is present in the application. Select a 2" pipe for the LU05 or LU12 Versions and a 3" pipe for all other models. The pipe length should run the measurement span. Cut a 45° notch at the bottom of the pipe and drill a 1/4" pressure equalization hole high in the dead band.

Stand Pipe

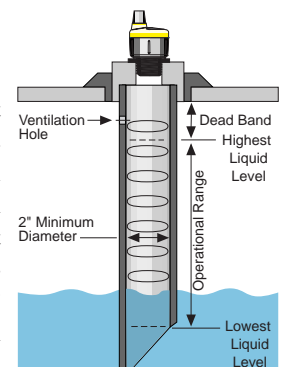

WIRING

Step Twelve

A. Wiring to a FLOWLINE LC52-1001 Controller

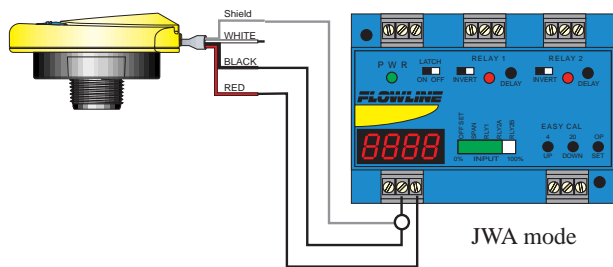

B. Wiring to a Typical Two-Wire Loop Powered Indicator

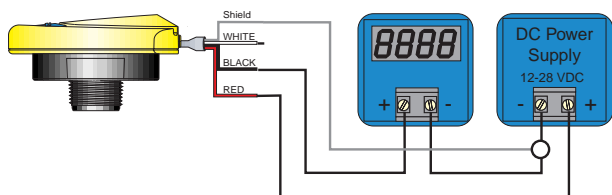

C. Wiring to a Typical Programmable Logic Controller

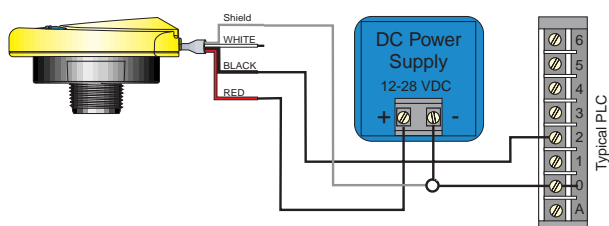

D. Wiring to a Flowline LI1_-1001 Universal Panel Meter

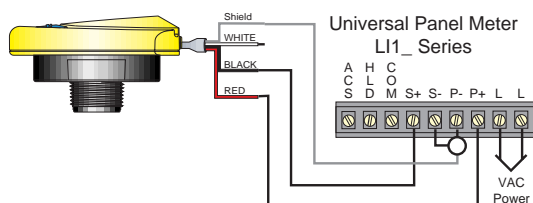

E. Wiring to a Flowline LI42-1001 MicroPoint Indicator

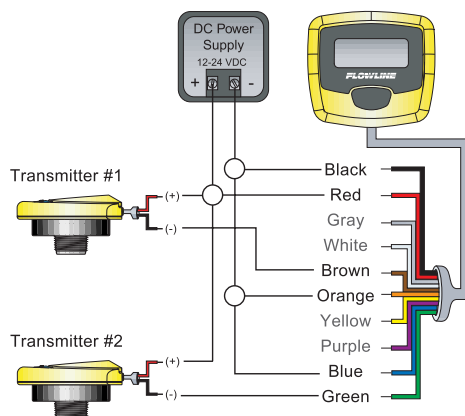

TROUBLESHOOTING

Step Thirteen

A. LED Status: During normal operation, the transmitter LED will be OFF and the 4-20 mA current will proportionately indicate level within the span. The following are the three LED diagnostic modes for troubleshooting:

LU_-5_1

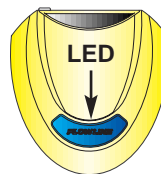

1. **Solid LED:** Indicates that the transmitter cannot identify the level. The current will hold at 22 mA until such time that the level is acquired. Check the installation (fitting, obstructions), application (level, foam, agitation, vapor) and transmitter (coating build-up or extreme condensation on transducer).

LU_-51_1

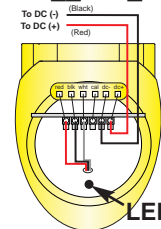

2. **Continuously Flashing LED:** Indicates that the level is outside of the transmitter's calibrated span and/or range. Check the level and recalibrate the span if required.

3. **Three Quick LED Flashed at Power Up:** Indicates that the transmitter is installed in a challenging installation fitting that may interfere with optimum acoustic signal transmission and/or receipt. The level should be more than 2' away from the transducer for valid feedback. See installation section and check to ensure that the transmitter is installed appropriately.

B. Testing the Transmitter

1. Connect a multimeter in series with the black wire to read the current output.
2. Verify that the current increases (tank filling) and decreases (tank emptying) appropriately in the calibrated span.
3. If not, carefully observe and attempt to correlate any installation, level or application event for more specific troubleshooting direction.

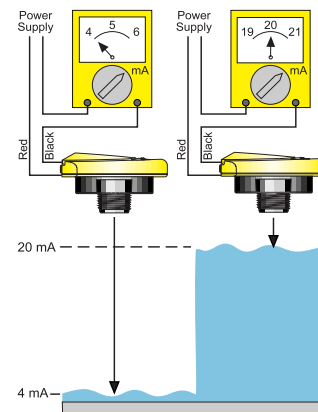

C. Factory Reset: Follow the below instructions to reset the transmitter to its original factory settings. Note that this will erase any previously input calibration set points.

1. If the transmitter is wired with power ON, turn power OFF to the transmitter and wait 30 seconds before continuing.
2. Connect the Black and White transmitter wires to the (-) terminal of the power supply.
3. Position the transmitter such that the transducer is pointed up into the air with no reflection target.
4. Add power to the transmitter for approximately 2 seconds and then power down.

Factory Set Points		
Transmitter	4 mA Setting	20 mA Setting
LU05-5_1	4.0' (1.2m)	2" (5 cm)
LU12-5_1	9.8' (3m)	4" (10 cm)
LU11-5_1	16.4' (5m)	4" (10 cm)
LU13-5_1	26.2' (8m)	8" (20 cm)

D. Additional Information: Go to www.flowline.com and click on the nav-bar "Application Info" button for FAQ's, tech-tips, case studies, white papers, glossary and success stories.