



955S Smart BRIK LDT Data Sheet

Magnetostrictive LDT In A Low Profile Package

The 955S Smart BRIK is an accurate, programmable zero and span, auto-tuning, non-contact linear position sensor in an economical, low profile package. The sensor utilizes our field proven magnetostrictive technology to give absolute position, repeatable to .01% of the sensing distance. The 955S Smart BRIK is a cost effective linear sensing solution.

The streamlined anodized aluminum extrusion houses the sensing element and electronics. The magnet slide moves over the sensing element that determines the position and converts it to a readable output. The 955S Smart BRIK is a self-contained unit and does not have a can or head assembly. All of the electronics are incorporated in the transducer which is less than one inch tall.

Units can be ordered in span lengths up to 180 inches long in 0.1 inch increments. The magnet slide is designed to move effortlessly along the transducer in guide tracks or a floating magnet assembly can be positioned above the unit. A variety of hardware is available for attaching the magnet slide to the moving portion of the process. The transducer can be ordered with 0 to 10 VDC, 4 to 20 mA, 0 to 5 VDC, -5 to 5 VDC, or -10 to 10 VDC output. All units are provided with a standard quick disconnect connector. A unique feature is the diagnostic

LED that remains green when a good magnet signal is present and when in the active programmed area. The LED turns yellow when the magnet is out of the programmed active range but still within the active stroke area. The LED turns red when there is no magnet present or the magnet assembly is out of the sensing area.

The transducer can be mounted vertically or horizontally using our mounting feet which slide on the lower part of the extrusion and clamp down when tightened. This packaging provides a compact and easy method of mounting for machine builders.

The 955S Smart BRIK is designed for applications where economical continuous feedback is necessary. The sensor can be a cost effective replacement to limit and proximity sensors and linear potentiometers. Applications include presses, blow molding, injection molding, extruding, roll positioning and many more.

As an added benefit, the 955S is FM approved for Class I, Div 2, Groups A, B, C, D applications when installed and wired per drawing E0241100 as shown in the manual. If your application does not require FM Class I, Div 2 approval, wire the 955S using a standard 4 pin Euro cordset from Ametek or others.

NOW
FM Approved
Class 1, Div 2

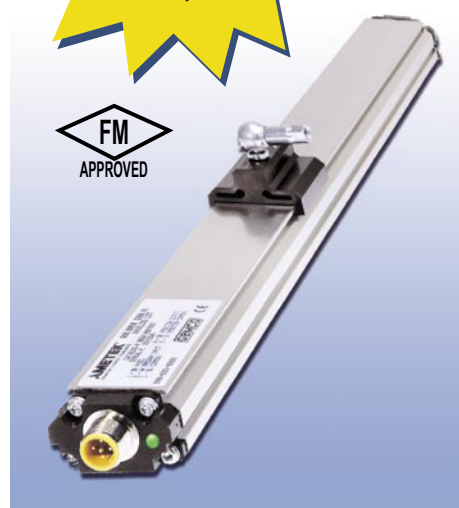

Specifications	
Input Voltage	10 to 30 VDC
Current Draw	100 mA Max.
Output	0 to 10 VDC 10 to 0 VDC -10 to 10 VDC 10 to -10 VDC 0 to 5 VDC 5 to 0 VDC -5 to 5 VDC 5 to -5 VDC 4 to 20 mA 20 to 4 mA
Linearity	+/- 0.05% of Full Stroke
Accuracy	+/- 0.1% of Full Stroke
Repeatability	+/- 0.01% of Full Stroke
Operating Temperature	-40° to 158° F (-40° to 70° C)
Span Length	4" to 180"
Null Zone	3"
Dead Zone	1.5"
Connectors	12mm Micro 4 Pin
Enclosure	IP67 Standard, IP68 Optional
Approvals	CE, FM Class I, Div 2
Specifications are subject to change without notice.	

955S Smart BRIK

Part Numbering

955S

955S Smart BRIK

VO

Output Type
V0 = 0 to 10 VDC
V1 = 10 to 0 VDC
V2 = -10 to 10 VDC
V3 = 10 to -10 VDC
V4 = 0 to 5 VDC
V5 = 5 to 0 VDC
V6 = -5 to 5 VDC
V7 = 5 to -5 VDC
C4 = 4 to 20 mA
C2 = 20 to 4 mA

0120

Stroke Length
 Insert stroke length to 0.1 inch. Enter as a four-place number. **Example:** A 12.0" stroke enters as 0120. To convert a metric stroke in millimeters, multiply millimeter value by 0.03937 to arrive at inch value.

Optional Approval
 Leave blank for no options.
E = Wet environment.
 Electronics sealed to IP68 Rating.

Dimension Drawing

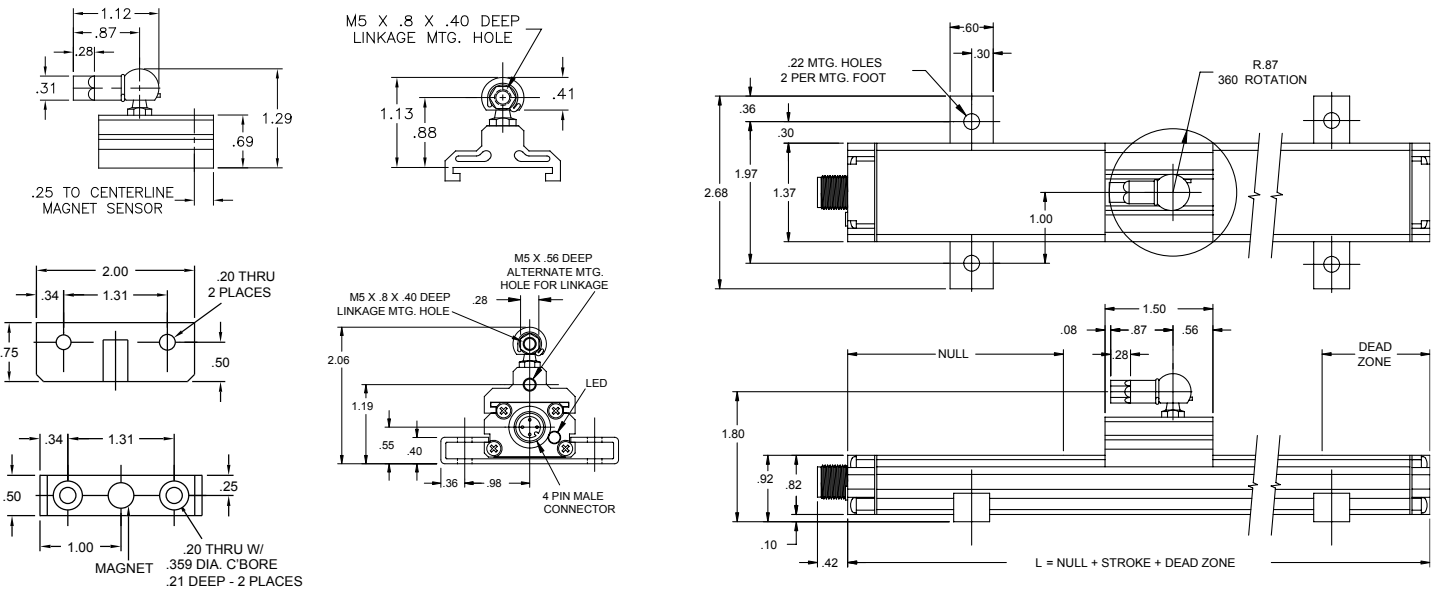

Accessories

Item	Part Number
Slide Magnet	SD0521800
Slide Magnet Side Adapter	SD0521801
Float Magnet	SD0522100
Mounting Foot	SD0522000
6 Ft. Cable	949001L6
12 Ft. Cable	949001L12
6 Ft. Cable, Right Angle Connector	949002L6
12 Ft. Cable, Right Angle Connector	949002L12
Control Arm	955ARMXX (X = Inches)
In-Line Programming Unit	955-1409
Rod Ends	04-570252

FM Accessories

6 Ft. Straight Cable	949024L6
12 Ft. Straight Cable	949024L12
Connector Lock	04-521570

NOTE: FM approved cordset and connector lock must be used and installed per drawing E0241100 when installing the 955S in Class I, Div 2, Group A, B, C, D applications.

Wiring Diagram

Use Euro Connector (micro 12 mm single keyway) cordsets, available from most connector manufacturers or purchased from Ametek. Install according to the following diagram:

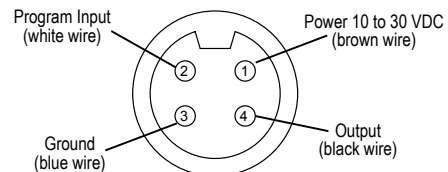

Connector View