



## INSTALLATION MANUAL

Ultra High-Speed Programmable Limit Switch

# 7500

## Ultra High-Speed PLS

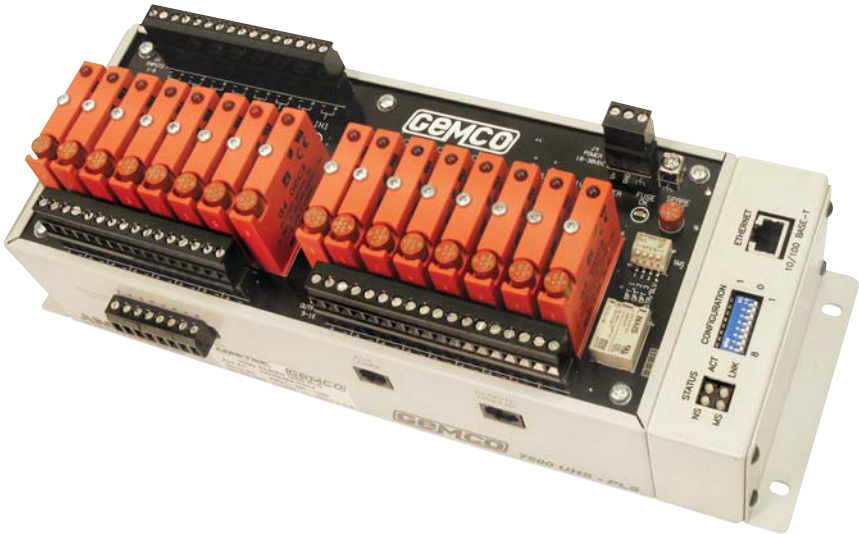

**ABSOLUTE PROCESS CONTROL  
KNOW WHERE YOU ARE... REGARDLESS**

## Preface

This manual is for the installation and maintenance of the Gemco 7500 Programmable Limit Switch.

AMETEK has checked the accuracy of this manual at the time it was printed. Any comments you may have for the improvement of this manual are welcome.

AMETEK reserves the right to revise and redistribute the entire contents or selected pages of this manual. All rights to the contents of this manual are reserved by AMETEK.



**WARNING:** Caution must be taken when adjusting limit outputs!

Disconnect power before servicing. The Gemco 7500 PLS contains no serviceable components other than relays and fuses. Consult factory for repair or replacement.

## Contents

Chapter 1 Introduction.....	4	6.8 Input Configuration Object (Class 0xC1, Attribute 34) .....	50
1.1 Standard Features.....	5	6.9 Add-On Test Object (Class 0xC1, Attribute 35) .....	57
Chapter 2 Hardware Overview .....	6	6.10 Offset Object (Class 0xC1, Attribute 36) .....	57
2.1 PLS Module.....	6	6.11 Program Control Object (Class 0xC1, Attribute 37) .....	58
2.2 Standard Features.....	8	6.12 Encoder Object (Class 0xC1, Attribute 38) .....	58
2.3 Resolver Assembly.....	11	6.13 System Info Object (Class 0xC0, Attribute 1) .....	59
2.4 Quadrature Encoders.....	13	6.14 Input Status Object (Class 0xC0, Attribute 2) .....	59
Chapter 3 Mounting and Wiring.....	15	6.15 Offset Information Object (Class 0xC0, Attribute 3) .....	61
3.1 Mechanical Installation.....	15	6.16 Configure RSLogix 5000 to Communicate with a 7500 PLS ...	62
3.2 Electrical Installation.....	16	6.15 Configure RSLogix 500 to Communicate with a 7500 PLS ...	67
3.3 Wiring Instructions.....	16	Appendix A Ordering Information.....	72
Chapter 4 Overview of Features.....	22	Appendix B Troubleshooting.....	73
4.1 Limit Switch Setpoints .....	22	Appendix C Specifications.....	75
4.2 Linear Speed Offset .....	24	Specifications .....	75
4.3 Minimum Speed Disable .....	26		
4.4 Add-On Test (Simulated Machine Movement).....	26		
4.5 Groups .....	26		
4.6 Inputs .....	28		
Chapter 5 Programming Basics.....	34		
5.1 Things to Consider Before Programming.....	34		
5.2 Initial Setup.....	35		
Chapter 6 ControlNet Network Programming.....	38		
6.1 ControlNet Comm Module.....	38		
6.2 Description .....	39		
6.3 Scheduled Messages.....	39		
6.4 Unscheduled Messages.....	41		
6.5 PLS Object (Class 0xC1, Attribute 1) .....	43		
6.6 High Speed Output Object (Class 0xC1, Attributes 2-17) .....	45		
6.7 Low Speed Output Object (Class 0xC1, Attributes 18-33) .....	48		

## Chapter 1 Introduction

The Gemco 7500 UHS is the fastest, most feature-rich programmable limit switch (PLS) available. This offering was designed specifically with the unique requirements of the high speed diaper/napkin and converting industries in mind. In fact, diaper and napkin manufacturers and machine builders worked with our engineers to design a product meeting the requirements of today and those of the next generation. This product is also ideal for high speed gluing, assembly and labeling applications.

The 7500 is a modular PLS with network communication capabilities. Rather than limit this versatile product to one PLC brand or specific backplane, the unit is designed to be DIN rail mountable or stand alone, and can be equipped with a network communication module to allow interface with various controllers. ControlNet and Ethernet I/P industry standard interfaces allow full integration of the PLS with the parent machine.

The 7500 incorporates Gemco's patented Ultra High Speed technology. Of the 32 total outputs, 16 operate at 5 microsecond scan times and are designed for the highest speed applications like adhesive system control. The remaining 16 outputs are ideal for the numerous lower speed applications that consume valuable I/O and processor time in the PLC.

The 7500 comes complete with eight hardware inputs and eight software inputs, for a total of 16. The inputs can be configured in any of 10 different trigger modes. Standard modes such

as Reset to Preset, Output Enable and Remote Setpoint Tuning are now accompanied by many new features specifically engineered to improve the performance of disposables lines. For example, new 'smart' input modes eliminate the occasional, random triggering of input sensors which cause expensive downtime. These inputs can synchronize an output pattern to a product entering a workstation, disable outputs if a product is not present, and allow dynamic fine-tuning of outputs from a remote location.

Input and output groupings further simplify programming and system operation. By combining the I/O into software groups that mirror the actual devices being controlled, operators and engineers alike find system setup, programming, and troubleshooting made easier and more logical.

Another huge advantage of the 7500 is that it operates with either encoder (quadrature) or 14-Bit resolver input. If your machine module does not have a 1:1 product registration, or if you simply have an encoder signal already available on the machine, the 7500 with quadrature input allows the use of incremental pulse trains instead of requiring a resolver input.

## 1.1 Standard Features

The following features are standard in every 7500 UHS PLS.

- 16 On board Ultra High Speed Outputs updated every 5 microseconds.
- 16 High Speed Outputs updated every 500 microseconds and transmitted over the network.
- Eight On board field configurable inputs for product presence, registration mark synchronization or remote setpoint advance/retard, to name a few.
- Eight Network configurable inputs for product presence, registration mark synchronization or remote setpoint advance/retard.
- Available with either a field programmable scale factor or quadrature incremental encoder input. Both are 14-Bit resolver input (16,384 count) resolution.
- Speed compensation/run up control advances/retards outputs over machine speed changes.
- Minimum Speed Disable for safety and quality control.
- Reset to Preset inputs for synchronizing outputs to leading edge of product.
- Output Enable Inputs signal critical events, improving quality and reducing down time.
- Event Capture Inputs allows confirmation that critical events have occurred at the right time and place in the process.
- The Add-On Test feature simulates machine movement when the machine is not running.
- Time Based Outputs fire at programmed positions and turn OFF after a specified dwell time.
- Remote Setpoint Tuning compensates for process drift.
- Automatic Stitching Output patterns significantly save programming time.
- Motion Detect output.
- Fault Check relay output provides an automatic, in circuit process to verify all major PLS functions are operating properly.

## Chapter 2 Hardware Overview

This section contains mechanical and electrical information on the 7500 UHS PLS main controller, remote operator interface, and resolver assembly. For specifications, see Appendix C. Features are discussed in the following order:

- 2.1 PLS Module
- 2.2 Standard Features
- 2.3 Resolver Assembly
- 2.4 Quadrature Encoders

### 2.1 PLS Module

The 7500 UHS PLS module is an electronic assembly that can be configured in many different ways. The following are mechanical features found on the module:

- 16 de-pluggable solid-state output relays are located on the I/O board of the controller with indicator LED and replaceable fuse.
- 16 output LEDs correspond to the state of the 16 Ultra High Speed output channels. When an LED is on, the output channel it corresponds to is energized. When an LED is off, the output channel is de-energized.
- Fuse tester/spare fuse. Each solid state relay is individually fused. A convenient spare fuse and fuse tester is provided for troubleshooting.
- Eight input LEDs correspond to the state of the eight high speed input channels.
- Eight optically isolated 10-30 VDC inputs are located on the I/O board of the controller.
- Auxiliary serial communications port is not currently enabled for customer use. Consult factory for special applications.
- Remote display port. Consult factory for special applications.
- Resolver input terminals allow connection to a Gemco resolver or compatible equipment.
- Quadrature input terminals allow connection to a customer supplied incremental encoder. +5 V @ 200mA is provided to power the encoder.
- Fault Check. The 7500 UHS PLS offers an on-line Fault Check which provides an automatic, in-process mechanism to verify that all major programmable limit switch functions are operating properly. The output is a mechanical relay, which remains energized during normal operation.
- Universal DC input power. The 7500 UHS PLS can operate over a wide input range of 10-30 VDC.
- The active and fault LEDs display the system's state. The active LED will turn ON when the PLS module is operating normally. The fault LED will turn ON when an error occurs during machine operation.

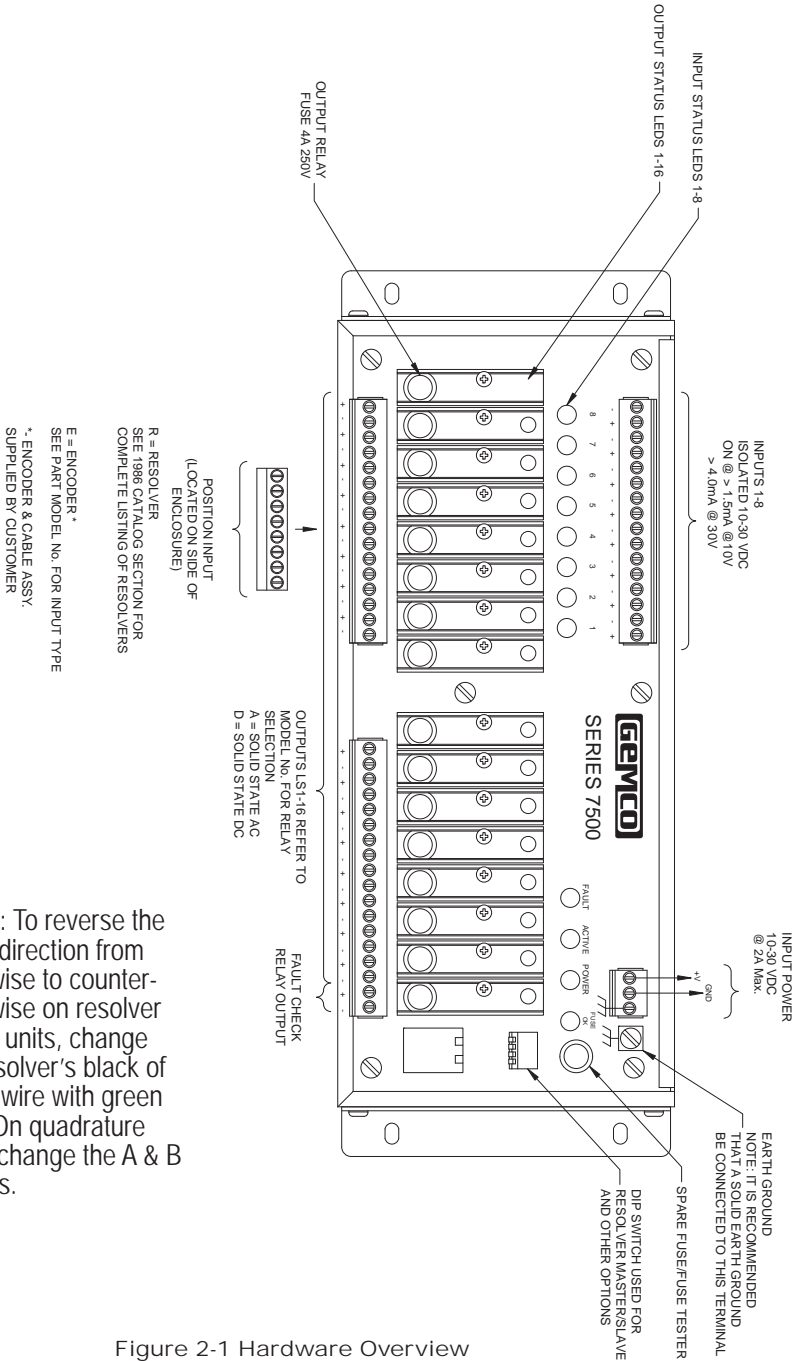

**NOTE:** To reverse the count direction from clockwise to counter-clockwise on resolver model units, change the resolver's black of green wire with green wire. On quadrature units, change the A & B phases.

Figure 2-1 Hardware Overview

## 2.2 Standard Features

### Scale Factor

The Scale Factor is the number of increments that the PLS counts through over one rotation of the resolver. For example, a PLS with a Scale Factor of 10,000 will count from 0 to 9,999 over one revolution.

### Offset

Offset is used to electronically synchronize the PLS displayed position with the actual machine position.

### Motion Detector

A programmable Motion Detector output will energize a user selected relay when the transducer speed meets or exceeds the user programmed RPM value.

### Fault Check

On-line Fault Check provides an automatic, in-process mechanism to verify that all major programmable limit switch functions are operating properly. The output is a mechanical relay, which remains energized during normal operation.

### Ten Input

Each input can be configured in ten different modes as either a reset configurations to preset input, an output enable input, remote setpoint tuning, or a 'Trigger Modes' output forcing input.

### Remote Setpoint Tune

The input must be programmed to either advance or retard the advance/retard setpoints. A single input cannot do both. Each time the remote input goes high, all setpoints of the associated outputs move by the same user programmed increment. This setting affects only the individual output(s) tied to the input.

In application, remote buttons at the adhesive guns can be mounted to allow an operator to advance or delay the location of the adhesive on the product.

### Remote Group Offset

Same as Remote Setpoint Tune, but the entire associated group advance/retard advances or retards.

### Reset to Preset (Standard)

When input activates, the associated output channels' resolver position is 'reset' to a user selected 'preset' value. The setpoints and other functions then run as programmed until the input is triggered again. In application, this is used to signal the presence of products that are continuously present.

### Reset to Preset (Single Shot)

Same principle as Reset to Preset (Standard), but the PLS functions work for only one resolver revolution after the input goes high. Then the outputs are disabled until the input is activated again. In application, this is used to continuously confirm the product presence for either randomly spaced products or for web applications.

### Reset to Preset (Average)

This feature mathematically averages the resolver position at which the input goes high, up to 32 cycles. The average of those positions is then used to change the machine offset position. Since neither the ON/OFF setpoints nor the Reset to Preset positions are affected when the input goes high, the machine offset position is the variable that can be updated every rotation to adjust the setpoints. In application, this prevents a random, out-of-position input signal, from triggering an output too far out of an expected location.



### Reset to Preset (Window)

This function only works if the input goes high in a programmable window of the resolver rotation. If the input is activated outside of the window, the output is disabled and does not respond. This is similar to Reset to Preset (Single Shot) with the exception that the input must be active within the window position.

### Output Enable (Level)

The input acts like an AND function. As long as the input is high, the output(s) can fire. When the input goes low, the output(s) are disabled and de-energized.

### Output Enable (Single Shot)

Functions the same as Reset to Preset Window except there is no reset value. The output simply has to go high within a programmed window or the associated output(s) are disabled until the next cycle. This input enables the output(s) until the start of the next window.

### Output Enable (Advanced)

This input type is similar to the output enable One Shot mode. The user must program a window in which the input will fire. The user must also program a position value at which the outputs will be enabled for one revolution. For example, the user has programmed the window to begin at position 100 and end at position 200 and the enable position value is set at 150. If the input is detected at position 120, the outputs will not be enabled until position 150 and then they will stay enabled for one full revolution of the resolver.

### Setpoint Data

There are up to eight setpoint pairs available per revolution for each output. This means that an individual output can be programmed to go ON and OFF up

to eight times per revolution. The user can add, delete, or change a setpoint in the list. Valid setpoints range from 0 to a value one less than the current scale factor. For example, if the scale factor is set at 1000, then valid setpoint values range from 0 to 999.

### Stitching Output Patterns

Each output is capable of having eight ON/OFF setpoint pairs. In cases where more than eight evenly spaced ON/OFF setpoints are required, the 7500 offers the stitching feature. This feature allows the user to add a start point and an ending point and the length of the ON and OFF dwells. The 7500 then automatically calculates the desired output pattern.

### Grouping

Grouping is an easy way to tie together multiple outputs that are to be controlled in the exact same manner. Grouping outputs makes programming easier. All outputs must be part of a group. In application, an adhesive gun with multiple solenoids is a typical group. Groups do not have to be consecutive outputs. For example, outputs 1, 7 and 11 can be a group.

A group can be comprised of both hardware outputs (1-16) and software outputs (17-32). Each group can have its own scale factor. This is very useful where different materials are used in a single manufacturing process. With each group having a programmable scale factor, the current position of a group will be displayed according to its own scale factor. The 7500 can be configured for up to eight different groups of outputs. Each group can be disabled until the machine reaches a programmable RPM value.

### Relative Offset

Relative Offset can be set, based on the current offset. For example, if the current offset is +10, and +13 is desired, the PLC sends a relative offset of +3. This takes a mathematical calculation out of the work of the PLC/user.

### Time Based Outputs

Time Based Outputs are programmed like standard outputs to turn ON at a specific resolver position and stay ON for a programmable amount of time. If Time Based Output is used, no other setpoints can be programmed for that output channel.

### Minimum Speed Disable

The Minimum Speed Disable function will disable the selected outputs when the actual RPM falls below the minimum speed programmed by the user.

### Linear Speed Compensation

Linear Speed Compensation allows the timing of the ON/OFF setpoints to adjust automatically to compensate for machine lag as line speeds vary. All 16 hardware outputs have individually adjustable speed compensation settings. The ON and OFF setpoints are adjusted independently.

The user selects the lower and upper RPM limits in which the outputs are compensated. Compensating the setpoints means determining how much earlier (in scale factor counts) the outputs must turn ON and turn OFF in order to keep the outputs' location in the desired position.

### Add-On Test (Simulated Machine Movement)

When the machine is not running, the 7500 can be programmed to fire the

outputs as if the line were running. The user programs the machine RPM and the desired simulation time. The outputs then cycle as if the machine were running at that speed for the desired amount of time. User selected outputs are enabled for this simulation.

### Input Capture

This feature stores the resolver group's position at which inputs transition ON and OFF. Data is stored for one revolution, then replaced by the next revolution's data. Like Output Enable (Single Shot), a window in which the input must transition, is programmable. If transition does not occur in the window, an error is generated.

### Position Input Devices

Either a Gemco resolver or incremental encoder (quadrature) input signal can be used. The unit must be configured at the time of manufacture for either resolver or encoder input.

Gemco Resolver  
Resolution 14-Bit (16,384)  
Scale Factor 2 to 65,535  
2000 RPM max.

Encoder/Quadrature Input  
Resolution 14-Bit max. (16,384)  
2000 RPM max.  
+5 VDC @ 200mA Supplied to the  
encoder from the 7500

### Status Groups (Process Information)

At any time, all vital process information can be obtained from the 7500, including:

- System Fault - A fault is a critical error that prohibits the outputs from operating. The source of the fault can be identified and includes resolver failure or PLS hardware failure.
- Configuration Error Data - This warning is a less severe error that does not prohibit the outputs from operating. The cause is precisely identified and is usually the result of an invalid parameter being programmed.
- Output Status - Individual status of each output.
- Input Status - Individual status of each input.
- Current Positions (Eight) - The current positions for end group.
- RPM - Resolver or encoder RPM is updated every 14 milliseconds.

#### Software Version

The version number consists of two words with the first word before the decimal indicating the major release number and the second word indicating the minor release number.

#### Force Outputs/Groups

This mode allows the user to enter a special mode of operation in which an input is used to force a PLS output or group of outputs to a specified state regardless of the resolver/encoders position and the setpoints. When the input is activated, the outputs can be

forced ON, forced OFF, or unforced depending how the input is defined. An input can be configured to force the output ON or OFF, but not both.

#### Enable Outputs

This bit is used to enable/disable the PLS outputs.

### 2.3 Resolver Assembly

The resolver assembly consists of a highly accurate and repeatable brushless resolver, housed in an industrial grade enclosure. The rotary shaft position is calculated from two analog signals that vary as a function of the angular position of the input shaft.

The resolver works on the same principle as a rotary transformer to couple power from the rotor into two stators. The resolver consists of a two-phase stator and a single-phase rotor. Each stator is positioned 90° apart from each other. The two stators continually provide two different output voltages. Using these two outputs, the PLS performs a ratiometric conversion which factors out electromagnetic interference (EMI) and provides an absolute position. See Figure 2-2. This results in a highly accurate and repeatable unit with excellent reliability.

The resolver assembly is contained in a rugged NEMA 4 enclosure with a plug-in connector. The input shaft is

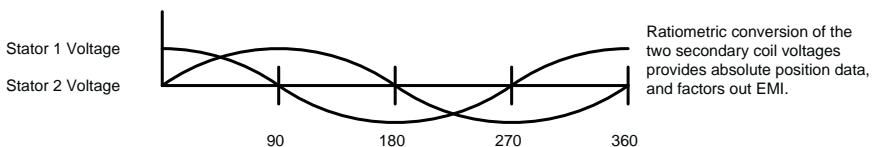

Figure 2-2 Voltages of Stator Coils

a 3/4 inch diameter and is made of stainless steel. It is mounted in sealed ball bearings with a radial load rating of 150 lbs. This results in the most rugged

duty transducer available for industrial applications. The operating temperature range is  $-40^{\circ}\text{C}$  to  $125^{\circ}\text{C}$ . See Figure 2-4 or 2-5 for the resolver dimensions.

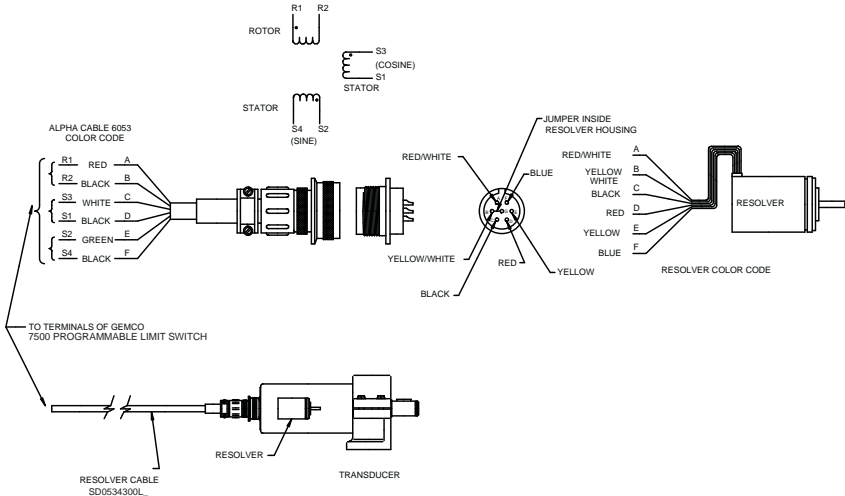
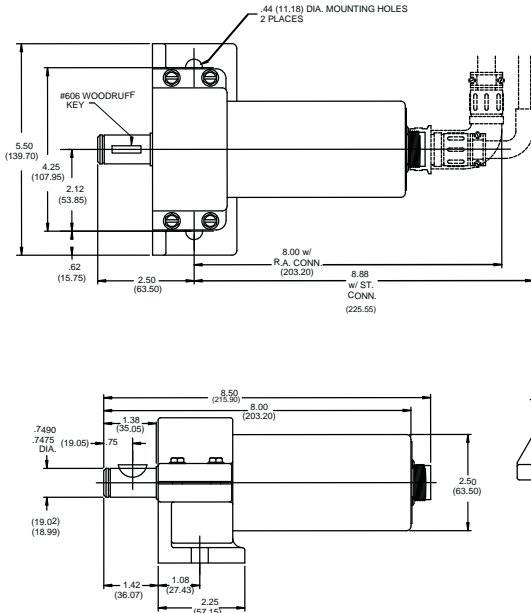

Figure 2-3 Resolver Wiring



NOTE: Other Gemco resolver assemblies are available. Contact factory for details.

Figure 2-4 1986A Brushless Resolver

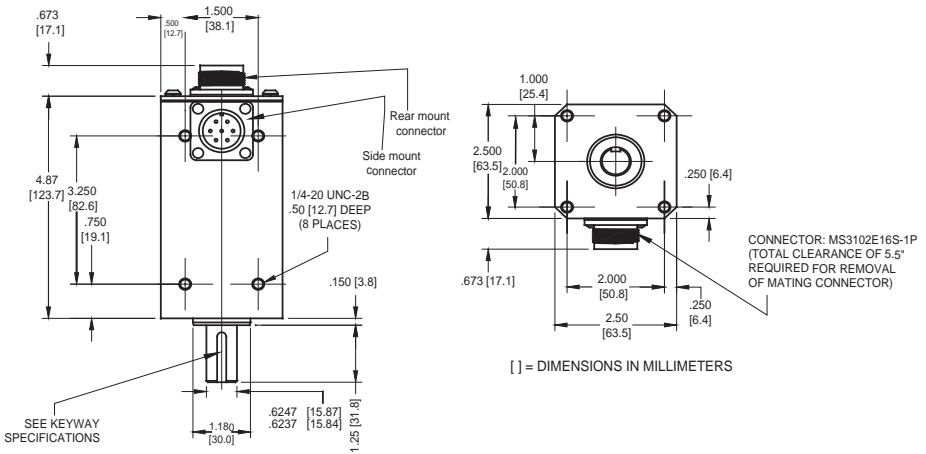

Figure 2-5 1986F Brushless Resolver

## 2.4 Quadrature Encoders

Encoders and cable assemblies are customer supplied.

The 7500 UHS is available with either a resolver or quadrature input. If your machine does not have a 1:1 product registration, or if you simply have an encoder signal already on the machine, the 7500 UHS with quadrature input allows the use of an incremental pulse train instead of a resolver.

NOTE 1: This feature needs to be specified at the time of order.

NOTE 2: When the quadrature feature is ordered the resolver fault checking circuitry is disabled.

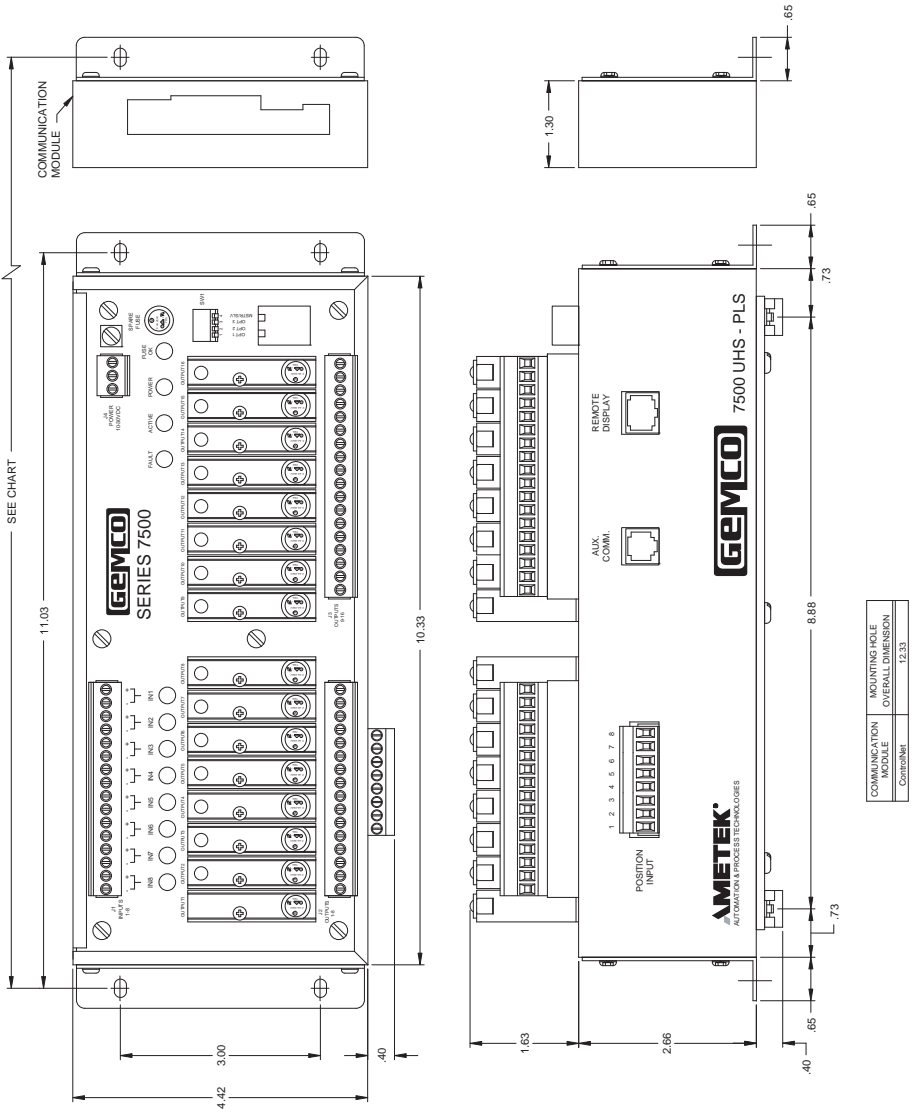

Figure 2-6 Dimension Diagram

## Chapter 3 Mounting and Wiring

This section describes the installation and wiring of the 7500 PLS family. Changes to these instructions should be made as necessary if special options and/or equipment are used. Topics are discussed in the following order:

- 3.1 Mechanical Installation
- 3.2 Electrical Installation
- 3.3 Wiring Instructions

Install the 7500 in an area free of water spray, corrosive gases, flying chips or other foreign matter. The operating temperature should be between 32 and 131 degrees Fahrenheit, with less than 95% relative humidity.

### 3.1 Mechanical Installation

#### Mounting the 7500 PLS

The 7500 PLS is designed to be panel or DIN rail mounted. Dimensions, mounting holes and sizes for each component are shown in Chapter 2.

Mount and securely bolt the controller into place using the four (4) 3/16" diameter mounting holes. A DIN rail mounting kit is supplied with all units, for an optional means of mounting. See Figure 3-1.

**NOTE:** In instances where the 7500 is being mounted directly on high vibration machinery, take care to isolate the controller from shock load and vibration.

It is always good design practice to mount the controller in the enclosure as far away from the motor starters and control relays as possible to minimize the effects of electromagnetic interference (EMI).

Route interconnecting wiring to minimize EMI coupling.

To attach DIN rail to the 7500 UHS unit, place the three supplied 8-32 x 3/8" long screws through the DIN rail bracket and firmly attach to the 7500 bottom.

#### Mounting the Resolver

The proper mounting of the resolver is critical to ensure the system's accuracy. There are many resolvers available. See Gemco's 1986 Resolver Catalog.

As a general rule, mount the resolver in an area free of excessive shock and connected in a 1:1 ratio with the machine.

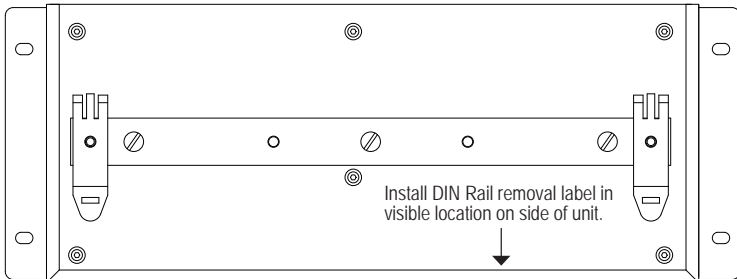

Figure 3-1 DIN Rail Mounting

## 3.2 Electrical Installation

The 7500 PLS is designed for use in an industrial environment and incorporates extensive transient suppression circuitry. However, the same general installation rules should be followed that are used on all microprocessor based equipment. Incoming DC lines should be from a clean power source and lines carrying computer level signals should not be routed in the same conduit as high voltage, transient producing circuits such as variable speed drives, welders or DC switching circuits.

This PLS is used with either a single turn resolver or incremental encoder. Wiring for this system is shown in Figures 3-2 through 3-10. These wiring diagrams are applicable for every standard 7500 PLS.

## 3.3 Wiring Instructions

This section contains pinout diagrams for each connector. The terminal wire size for all connectors is No. 22-12 AWG.

### Grounding

We recommend that all equipment and components of a machine have a common earth ground point connected to their chassis. A properly grounded system provides a path for short

circuit protection. Grounding the 7500 minimizes shock hazards to personnel and damage to equipment caused by short circuits, transient over voltages, and accidental connection of energized conductors to the 7500 chassis.

The 7500 earth ground lug and the three-place de-pluggable power connector's earth ground terminal are internally connected. It is recommended that a permanent and continuous wire be attached to the ground lug to provide a low impedance path to earth ground.

The National Electrical Code contains grounding requirements, conventions, and definitions. Follow all applicable local codes to safely ground the system.

### External Power Supply

The 7500 draws its power from an external power supply. The output voltage from the power supply must be between 10 to 30 VDC and be able to provide a minimum of 10 watts of power.

**NOTE:** It is recommended that the 7500 be powered from a clean supply. If a system supply is used, this supply must not be used to switch large inductive loads such as relays or solenoids without proper surge suppression installed on these loads.

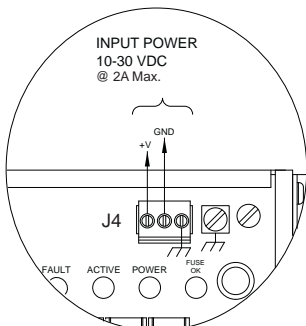

Input Power  
The Main Controller has a universal input power supply. Input power is 10-30 VDC @ 10 watts.

Figure 3-2



### Resolver Input

The resolver input has an eight position connector. See Figure 3-3. Attach the pre-wired plug on the resolver cable to the resolver and route the shielded cable through a separate grounded (earth ground) metal conduit to the panel. Connect the mating half terminal block to the 7500. To change count direction switch green (pin 5) and black of green (pin 6).

**NOTE:** When extensions to the factory supplied resolver cable are necessary, a junction box should be used to connect the wire leads and cable shields from one cable to the other. The junction box is used to isolate the splices of the connecting wires from outside electrical noises. Ground the cable shields at the controller case only.

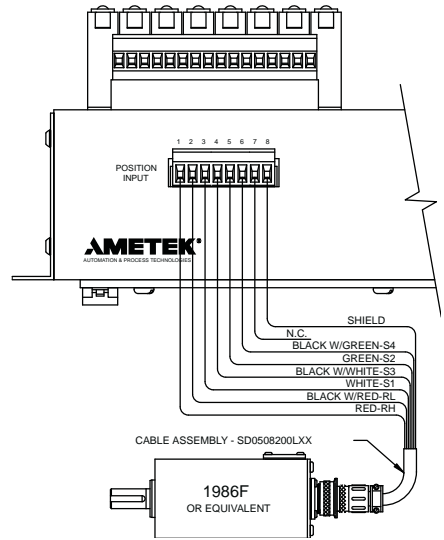

Figure 3-3 Resolver Input

When using a cable other than the standard SD0534300LXX, the shield must be tied to Pin 8 and must not be tied at the resolver end.

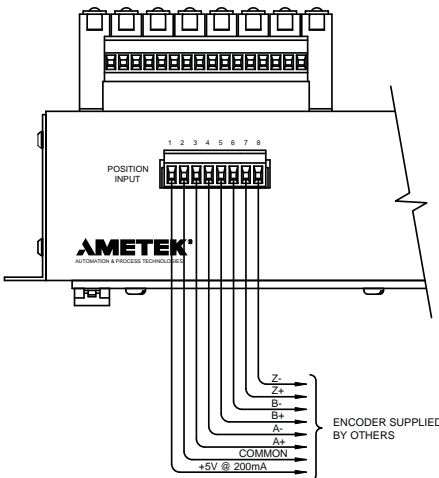

Figure 3-4 Encoder Input

### Encoder Input

The encoder input has an eight position connector. See Figure 3-4. The encoder and associated cables are customer supplied. The cabling should run through a separate grounded (earth ground) metal conduit to the panel.

The encoder input is designed for an incremental RS422 differential input. Terminals 1 and 2 provide 5 volts DC at 200mA to power the encoder.

**NOTE:** For other encoder input options consult factory.

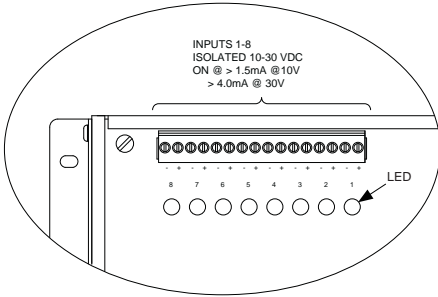

### Hardware Inputs 1-8

The 7500 has eight hardware inputs. The inputs connector (J1) is a 16 position connector. Inputs 1-8 are optically isolated and do not share a common ground. These inputs can accommodate either PNP (sourcing) or NPN (sinking) type input signals. For wiring examples, see Figure 3-9.

Figure 3-5 Hardware Inputs

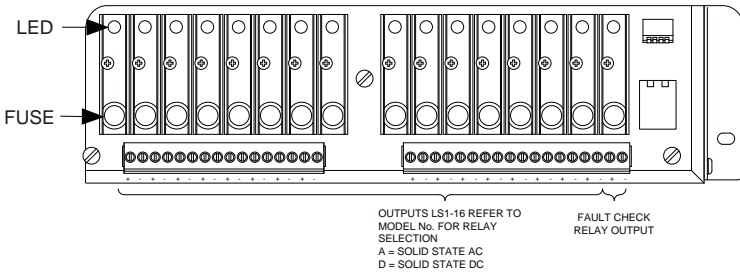

### Output Relays

The 7500 is available with any combination of solid-state AC or DC output relays. There is a 16 place connector that contains limit switch outputs 1-8 (J2), and an 18 place connector (J3) for limit switch outputs 9-16 and the Fault Check output relay. For output and Fault Check wiring, see Figure 3-10.

Each solid-state output is individually fused with a 4 amp fuse. A fuse tester and spare fuse are conveniently located on the main board in the upper right corner.

NOTE: The output status LED will continue to operate even if the fuse is blown.

Figure 3-6 Output Relays

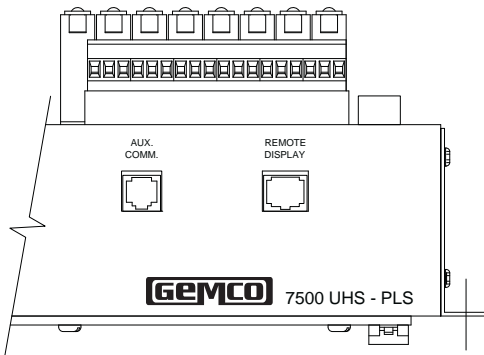

### Auxiliary Com Port

The auxiliary RS485 communication port uses a standard RJ11 connector. Consult factory for use and protocol options.

Figure 3-7 Auxiliary Com Port

## Master / Slave Connections

Before powering up the PLS, the module's dipswitch (SW1) must be configured. See Figure 3-8. The dipswitch has four switches. The positions of switches 1, 2 and 3 are for future options. The position of switch 4 determines if the PLS will act as master (module drives a reference signal to the resolver) or slave. If there is one PLS module connected to a resolver, it must be configured as a master. When daisy-chaining multiple PLSs, only one module (master) can drive a reference signal to the resolver. All other 7500 units connected to the same resolver should be set to slaves.

**NOTE:** It is possible to have multiple slave 7500 UHS PLSs attached to the same resolver or encoder. Factory tests have indicated that at least ten 7500 UHS PLSs connected to the same resolver, using short cable lengths (approximately 100 feet or less) will function properly. The resolver fault check circuitry indicates a fault condition when the slave device, or devices, is separated from the master 7500 UHS PLS's cable link.

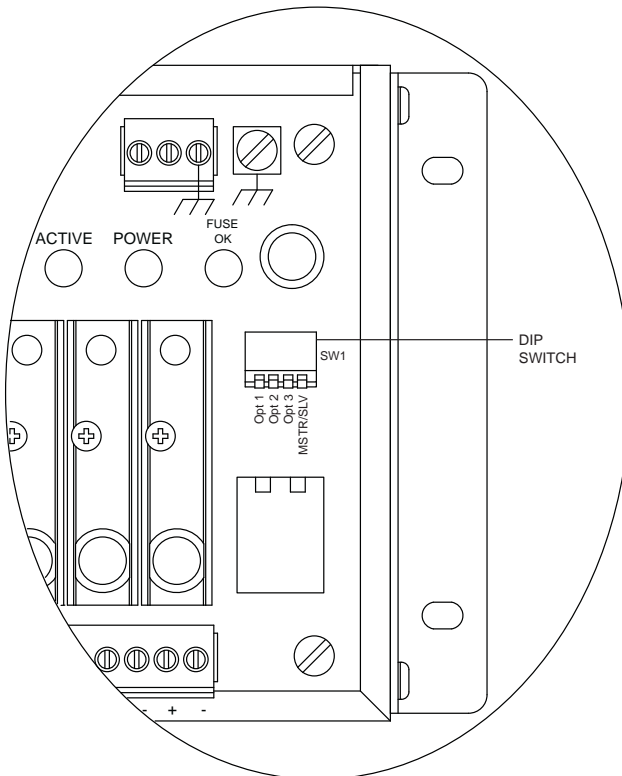

Figure 3-8 Master/Slave Connections

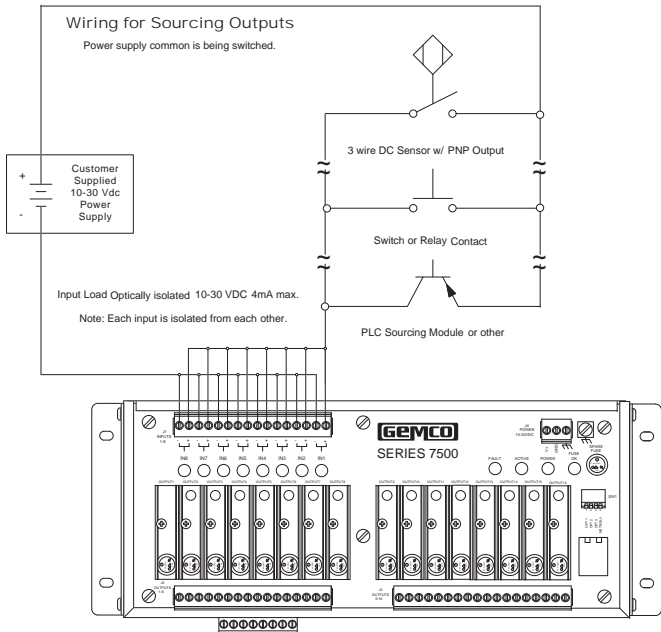
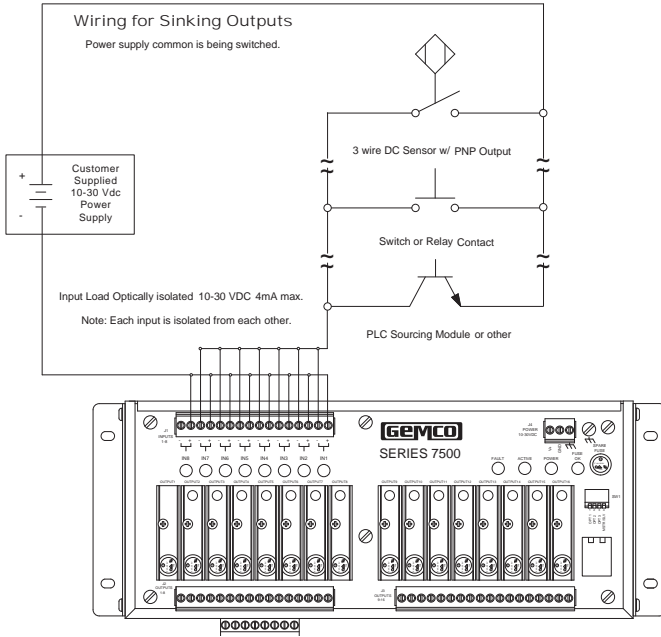
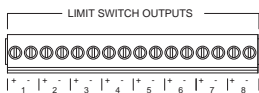

Figure 3-9 Control Input Wiring

## Input Wiring Guidelines

- Inputs can be wired for sinking or sourcing.
- An external power supply must be used to power inputs.
- Inputs will operate with voltages from 10-30 VDC.
- Each input will draw 4.0mA max.
- A combination of mechanical and solid state devices can be used.
- Each input is optically isolated and does not share a common ground.
- With mechanical switches, you can either break to + or - input.
- Voltage must be present across + and - terminals for input to turn on.

## Output Terminal Strip



AC OUTPUT  
24-280 VAC 3 AMP MAX.

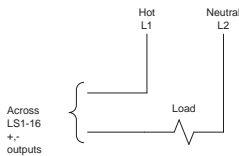

Note: L1 or L2 can be broken with the solid state output relay.

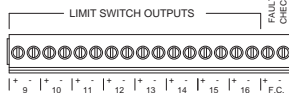

DC OUTPUT  
5-60 VAC 3 AMP MAX.

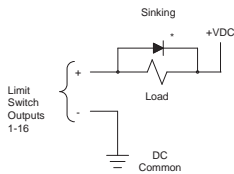
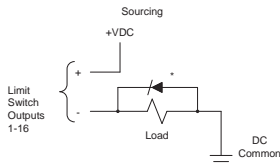

\* Commutation diode must be used on inductive loads.  
Typically use IN4005.

### FAULT CHECK OUTPUT

Recommended wiring of Fault Check relay

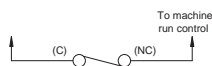

Machine should be wired so that de-energized fault check relay will immediately stop machine. If no fault check is needed, do not connect fault check relay into machine run circuit.

### CONNECTIONS TO AC OUTPUT MODULE

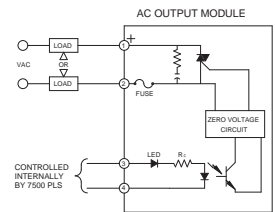

### CONNECTIONS TO DC OUTPUT MODULE

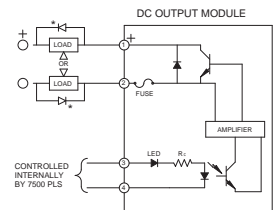

\* Commutation diode must be used on inductive loads.  
Typically use IN4005.

Figure 3-10 Control Output Wiring

## Chapter 4 Overview of Features

See Chapter 5 for basic programming information on the features covered in this chapter.

This chapter describes the 7500 UHS PLS special features. For example, it will show how output channels are affected by Linear Speed Offset or Reset to Preset inputs. Features are discussed in the following order:

- 4.1 Limit Switch Setpoints
- 4.2 Linear Speed Offset
- 4.3 Minimum Speed Disable
- 4.4 Add-On Test  
(Simulated Machine Movement)
- 4.5 Groups
- 4.6 Inputs

### 4.1 Limit Switch Setpoints

This section describes the programming of limit switch setpoints which are ON/OFF relay outputs based upon the resolver or encoder position. A dwell is the number of scale factor counts between the programmed ON and OFF positions. All output channels can be programmed for multiple ON/OFF dwells over one rotation of the resolver or encoder. There are four types of setpoints:

- Standard Setpoints
- Stitching Setpoints
- Time Based Setpoints
- Motion Detect Setpoints

#### Standard Setpoints

A standard setpoint is used to program an output channel to energize and de-energize over a dwell, or multiple

dwells where spacing and duration are randomly positioned over one resolver rotation. Programming a setpoint is based on the group's programmed scale factor. For example, assume the resolver is set for a 360° scale factor. If an output channel were programmed to energize at 180° and de-energize at 270°, it would function as shown in Figure 4-1.

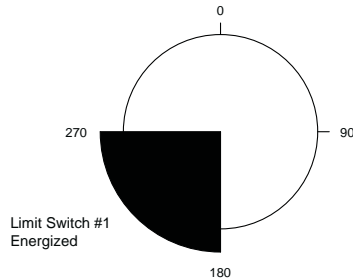

Figure 4-1 Programmed Output Channel Based on a 360° Scale Factor

Setpoints are programmed in ON and OFF pairs. You can also program multiple ON/OFF dwells on any output channel. Up to eight setpoint pairs can be programmed for a single output. As a result, an output channel can become energized and de-energized multiple times during one rotation of the resolver. Figure 4-2 illustrates an output channel becoming energized from 20-80°, 100-180°, and 200-270°.

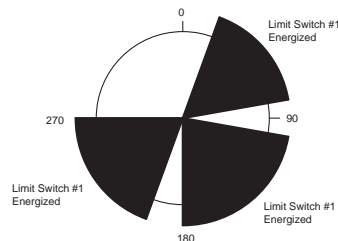

Figure 4-2 Multiple ON/OFF Dwells for a Single Output Channel

## Stitching Setpoints

A stitching setpoint is used to program an output channel to energize and de-energize numerous times within a programmed starting and stopping position. Unlike an output channel programmed with multiple intermittent ON/OFF dwells, output channels programmed with stitching setpoints repeat the same ON/OFF dwell a series of times like a sewing machine making a series of stitches in fabric. This function can be used to drive a glue gun to apply many small drops of glue spaced

evenly across the length of a product. Using stitching setpoints reduces programming to four easy steps instead of programming numerous ON/OFF positions. Figure 4-3 illustrates stitching patterns programmed on an output channel.

NOTE: The output can be configured with seven standard setpoint pairs and one stitching setpoint array. This allows infinite ON/OFF setpoints for a given output.

Words Programmed for a Stitching Operation

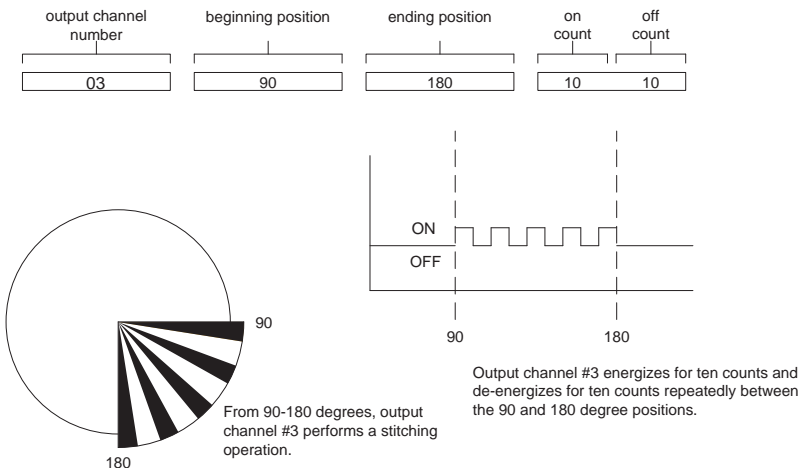

Figure 4-3 Positions for a Stitching Operation

**SPECIAL NOTE:** This same stitching pattern sequence can be used to program an incremental output from one of the limit switch output channels. This incremental output can be fed to an external drive or controller. To program, set the beginning position at zero and the

ending position at the maximum scale factor count. Calculate the appropriate on count and off count duration to provide the desired number of pulses per revolution. The output can be used 90° out of phase to generate an incremental "quadrature" encoder signal.

### Time Based Setpoints

Time Based Setpoints are used in order to have outputs or groups of outputs actuate based on resolver/encoder position and turn OFF based on time. Any or all of the 16 on-board outputs can be configured for time based operation. If an input is time based, no other setpoints can be programmed. Valid selections are from .001 to 65.535 seconds.

### Motion Detect Setpoints

Any of the 32 outputs can operate as a motion detect output. This output will energize upon reaching a programmed RPM value and will de-energize as the RPM drops below the selected RPM value. Typical uses for this feature include latching in a machine operation when a desired operating speed is reached or for detecting a broken coupling or chain driving the resolver/encoder.

## 4.2 Linear Speed Offset

Linear Speed Offset allows output channels 1-16 to be individually programmed to advance or retard depending on the speed of the resolver or encoder. This function compensates for the mechanical lag in glue guns and actuators that must be precisely synchronized with the moving product.

The values assigned in the Linear Speed Channel establish the rate (counts per RPM) for the specified output. A different rate of change can be programmed for the leading edge (ON offset) and the trailing edge (OFF offset) of the ON/OFF dwells on the selected output channel,

as well as the speeds at which the speed compensation will start and end.

NOTE: Linear speed offset only works for forward rotation. A reverse rotation, or negative RPM indication, will always produce an offset value of zero regardless of the absolute RPM value.

The linear speed compensation is calculated using a minimum RPM, or starting point, and a maximum RPM, or stopping point.

The starting point consists of the RPM value at which the linear speed compensation is to begin and the starting on counts or off-counts that the setpoint is to be shifted by.

The stopping point consists of the RPM value that the linear speed compensation is to stop at and the ending on or off counts the setpoint is to be shifted by.

Figure 4-4 shows a simple gluing application. A conveyor moves a carton under a glue gun, which dispenses glue onto the flaps. The resolver/encoder is connected in a 1:1 relationship so that one revolution is equal to one carton.

For example, assume that we programmed output channel 1 to come ON at 90 degrees and go OFF at 270 degrees. At 50 RPM we want to start to linearly offset the setpoint so that by 150 RPM we have offset the ON position by 10 degrees and the OFF position by 5 degrees.

In order to do this, the start RPM is set at 50 RPM with the ON offset set to 0 and



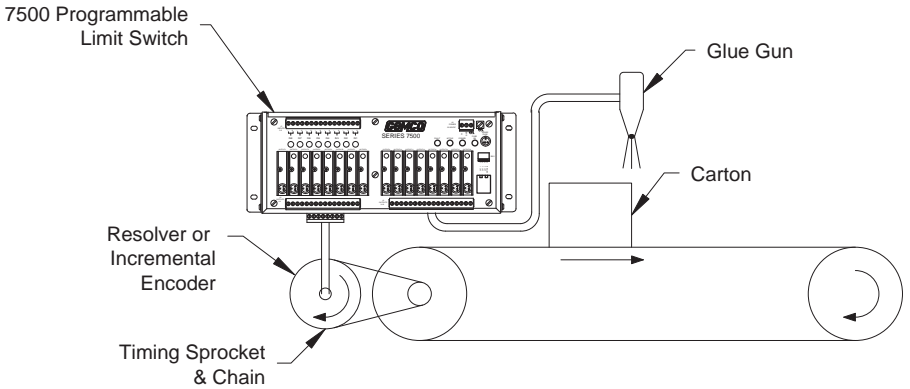
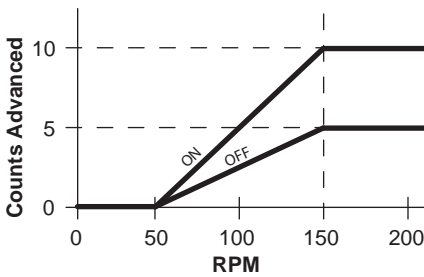

Figure 4-4 Linear Speed Offset Application



The ON setpoints advance by 10 counts and the OFF setpoints advance by 5 counts as the resolver or encoder increases to 150 RPM. The rate of advance is applied linearly as the RPM moves above the linear speed start RPM and toward the linear speed stop RPM.

Figure 4-5 Linear Speed Offset Graph

the OFF offset set to 0. The stop RPM is set at 150 RPM with the ON offset set at 10 degrees and the OFF offset set at 5 degrees. This rate of advance is applied linearly as the speed increases from the user programmed linear speed RPM start point (in this case 50 RPM) and will continue linearly as speeds increase to the linear speed RPM stop point (in this case 150 RPM). In other words, at 50 RPM or less, the setpoint will turn ON at 90 degrees and go OFF at 270 degrees. By 100 RPM, the setpoint will have

shifted so that it turns ON at 85 degrees and OFF at 267.5 degrees. At 150 RPM or greater, the setpoint will turn ON at 80 degrees and turn OFF at 265 degrees. This is illustrated in Figure 4-5.

The ON setpoint advances by 10 counts and the OFF setpoint advances by 5 counts as the resolver/encoder increases to 150 RPM. The rate of advance is applied linearly as the resolver/encoder moves above the linear speed start and the linear speed stop RPM.

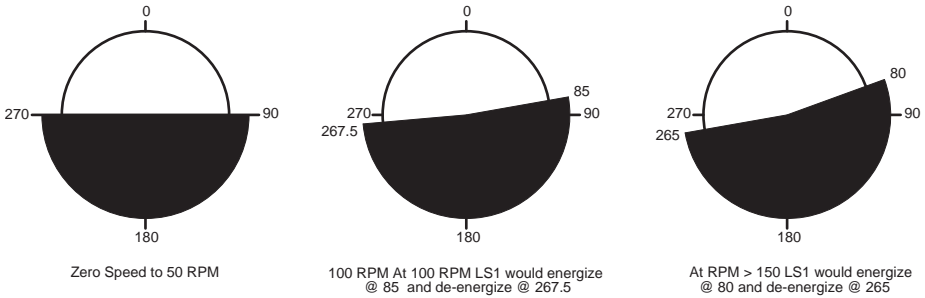

Figure 4-6 Linear Speed Compensation at Various Speeds

### 4.3 Minimum Speed Disable

This feature allows selected limit switch output channels to be automatically turned off if machine speed drops below a programmed RPM value. It can also be used to prevent output channels from turning on until a desired operating speed is reached. Typical uses include turning off glue guns or retracting actuators to a safe position under emergency stop conditions.

### 4.4 Add-On Test (Simulated Machine Movement)

The Add-On Test feature tests outputs as if the production line were running, even though it is stationary. Previous methods were expensive and inaccurate because the PLS did not actually fire the intermittent patterns that are used during production.

This feature allows the firing of designated outputs (or groups of outputs) at simulated line speeds. For example, to confirm proper operation of outputs 1-4 at a line speed of 1000 feet/minute, you would select the outputs (1-4). The

line speed to simulate (1000 RPM), and the duration of the test (60 seconds). The test is then initiated and only the selected outputs fire their programmed patterns as if the line were running at 1000 RPM. At the end of 60 seconds, the test concludes and the outputs return to stand-by.

All outputs relying on output enabler type inputs to turn ON would automatically be enabled even though the enabler inputs were not firing in simulation mode.

### 4.5 Groups

Grouping is an easy way to tie together multiple outputs that are controlled in the exact same manner. The 7500 UHS has a maximum of eight groups, each group having its own scale factor, position, offset and minimum speed disable. In order for an output to work, it must be a member of a group.

### Group Setup Parameter

Before programming, it is recommended to set the Group Setup Parameters. These parameters establish which outputs are in the group, the scale factor for the group, the input operating mode for the group, and the group offset. Multiple inputs can be configured for a group and can be configured to only effect certain outputs within a group.

### Outputs

Groups can be comprised of both hardware outputs (1-16) and software outputs (17-32). Outputs assigned to a group do not have to be in consecutive order. For example, outputs 1, 7, and 11 can be a group.

### Inputs

Multiple inputs can be tied to a group.

### Scale Factor

Every group can have its own scale factor. This is very useful when different materials are used for a single manufacturing process.

With each group having its own scale factor, the current position of a group will be displayed according to its own scale factor.

### Position

Each group tracks its own position. Each group position can be monitored and modified by the user.

### Offset

Each group can be offset with either an absolute offset or a relative offset. A relative offset figure can be set, based on the current offset. For example, if the current offset is  $+10^\circ$ , and  $+13^\circ$  is desired, the PLC sends a  $+3^\circ$  instead of  $+13^\circ$ . This takes the mathematical calculation out of the work of the PLC/user and also allows for an offset while the machine is running.

### RPM Disable

Within each group, you can specify which outputs are to be effected by the RPM Disable feature. An output set to RPM Disable will not operate below the specified RPM.

The table below shows which options can be configured in the group mode.

The inputs and certain features can be configured to effect a specific output group or a set of individual outputs selected by a bit mask. Each input can control all outputs in a group or only specified outputs. A table illustrating these capabilities is provided below.

	Group Outputs	Individual Outputs (Mask)
Reset to Preset (Standard, Single Shot, Average, Window)	X	X
Output Enable (Level, Single Shot, Advanced)	X	X
Force ON/OFF	X	X
Remote Setpoint Tune		X
Remote Offset Tune	X	
Add On Test		X
Minimum Speed Disable		X

## 4.6 Inputs

This section describes the eight hardware inputs and the eight network inputs. Each input can be tied to a group of outputs. Hardware Inputs 1-8 are optically isolated and do not share a common ground. The inputs can accommodate either PNP (sourcing) or NPN (sinking) type input signals. For wiring examples, see Section 3.3. A status LED for each input is conveniently located on the top of the controller next to the input connection terminal block.

These eight inputs are arranged on a 16 place terminal strip. Each input is optically isolated and must be powered from an external DC power source, (i.e. a contact closure just across the input terminals will not assert an input). Many types of hardware can drive these inputs, including mechanical switches, relay contacts, DC three wire sensors, three wire proximity sensors, solid-state DC output modules, and PLC DC outputs. See Figure 3-10 for wiring diagram.

### Input Functions

- Reset to Preset (Standard)
- Reset to Preset (Single Shot)
- Reset to Preset (Average)
- Reset to Preset (Window)
- Output Enable (One Shot)
- Output Enable (Level)
- Output Enable (Advanced)
- Remote Setpoint Tune (Phasing)
- Remote Position Tune (Offset)
- Output Forcing
- Group Forcing
- Input Capture

### No Input

No Input type has been configured for this input. The controller will ignore any activity on this input when it is in the No Input mode.

### Reset to Preset

The Reset to Preset input allows selected output channels to be reset to a programmed position value upon seeing an input from a remote sensor. This type of input is typically used in applications where parts are randomly spaced as they enter the workstation.

A photoelectric or proximity switch is used to sense the leading edge of the product. Upon seeing the leading edge the output channels can be reset to a user specified preset position value. The output channels will then begin to operate based on their ON/OFF setpoints relative to the preset value.

Because the Reset to Preset input resets the output channel's positions when it senses a part entering the workstation, it doesn't matter at what position on the encoder a part enters the workstation.

In Figure 4-7, output channel 1 has been programmed to have a Reset to Preset value of zero. During machine operation, input channel 1 becomes energized at machine position 180°. If output channel 1 is linked to input channel 1, it resets to 00. In this way, the outputs energize at the proper position, according to their ON/OFF setpoints and relative to the position at which the input was energized. There are four modes of operation for the reset inputs. They are as follows:

### Reset to Preset (Standard)

The selected group of output channels reset to the preset position value upon sensing the input. The setpoints will continuously operate over their programmed values. As the resolver continues to rotate through zero, the output channels will continue to track the

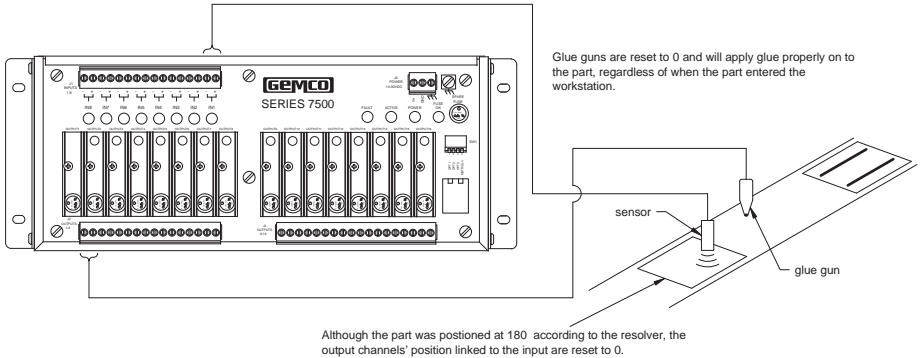

Figure 4-7 Output Channels Reset to Zero When Part is Sensed

reset resolver position and the setpoints will operate at their programmed values.

#### Reset to Preset (Single Shot)

The selected group of output channels reset to the preset position value upon sensing the input. The setpoints will operate over their programmed values through one rotation of the resolver. After one complete revolution, the output channels will remain de-energized until the next reset input is sensed.

#### Reset to Preset (Average)

The 7500 will mathematically average the resolver position at which the input goes high. The user can specify how many to average and can be up to the last 32 cycles. The average of those positions is then used to change the machine offset position. Since neither the ON/OFF setpoints nor the Reset to Preset positions are affected when the input goes high, the machine offset position is the variable that can be updated every rotation to adjust the setpoints. In application, this prevents a random, out-of-position input signal from triggering an output too far out of an expected location.

#### Reset to Preset (Window)

This Reset to Preset mode only works if the input goes high in a programmable window of the resolver rotation. If the input is activated outside of the window, the outputs are 'disabled' and do not respond. This is similar to Reset to Preset (Single Shot) with the exception that the input must be active within the window position.

Figure 4-8 shows three different glue heads in different locations on the conveyor being controlled by a single controller and resolver/encoder. Any or all of the available 32 outputs can be configured as a Reset to Preset without compromising the update time of the controller. The spacing between the parts being glued is random. Each output on the controller is capable of keeping track of its own position.

The input type sensors are connected to the input terminals. When a sensor detects a product, it resets the corresponding output's position to the preset value and enables that output to turn ON for one revolution of the resolver. After one complete revolution, the output

channel will remain de-energized until the next reset input is detected.

### Output Enable

Output Enable inputs are used to enable or disable groups of selected output channels based upon sensing a critical event prior to or during each rotation of the resolver. Typical uses include verification that a product is present at a glue station prior to allowing the glue guns to operate. There are three different Output Enable modes:

#### Output Enable (One Shot)

In One Shot mode, a window is programmed in which the input must change state in order to allow the linked output channels to operate over the current rotation of the resolver. If the input does not change state within the programmed window, the linked outputs will not operate. In Figure 4-9, the Output Enable input (input channel 3) is linked to output channels 5 and 7. When the input senses the part, the glue guns (controlled by the output channels) are enabled, and will apply glue onto the part according to their ON/OFF setpoints. However, if a part is not sensed within the programmed window, the linked output channels will be disabled through that rotation of the resolver.

**NOTE:** The Output Enable feature is similar to the Reset to Preset (Single Shot), however Output Enable does not modify the position, it simply allows outputs to activate.

#### Output Enable (Level)

The Level mode operates like a simple AND function. The output pattern will only operate as long as the Output Enable input is energized. Therefore, the

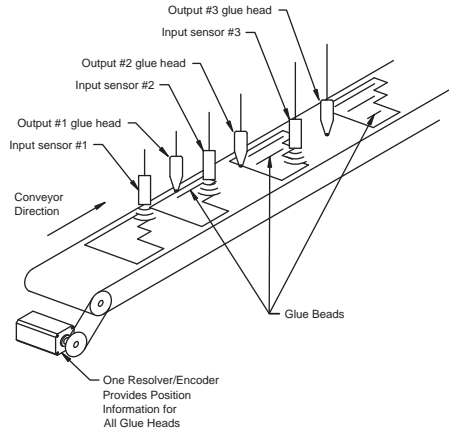

Figure 4-8 Sample Application

product presence sensor must provide an input during the full duration of the limit switch output pattern. If the input goes to the inactive state, the output channel will de-energize. The input can be programmed to be active high or active low so the AND feature will enable the outputs when its input is high or low.

#### Output Enable (Advanced)

This input type is similar to the Output Enable (One Shot). The user must program a window in which the input will fire. The user must also program a position value that will enable the outputs for one revolution. For example, the user has programmed the window to begin at position 100 and end at position 200 and the enable position value is set at 150. If the input is detected at position 120, the outputs will not be enabled until position 150 and then they will stay enabled for one full revolution of the resolver.

#### Remote Setpoint Tune (Phasing)

Remote Setpoint Tune inputs can be used to advance or retard a selected

Chart represents the input channel #3's window of detection (35 to 45) and the input's actual transition. Notice that the input detection window closes before the output channels' first on/off dwell.

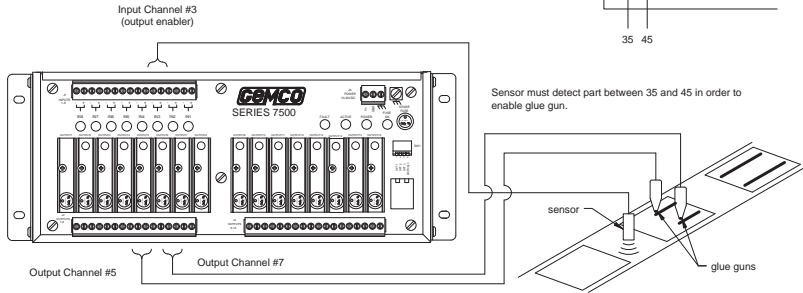
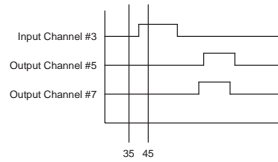

Figure 4-9 Output Enable Input (One Shot) Enables Output Channels

output channels from a remote location, see Figure 4-10. Actuation of the advance/retard input will move all setpoints on the selected output channels forward/backward in predefined (programmable) increments. Operators can watch these changes and make small adjustments to the outputs while standing at the workstation where the actuators are located. Any of the 16 inputs can be configured for this mode.

This feature can also be used to automatically fine tune output patterns for proper placement. Any dynamic sensing circuit that monitors the final placement of an assembly process can be used to automatically actuate these inputs. The input capture capabilities could be used to monitor the position at which an assembly event occurs. This data can then be used to advance or retard the outputs through logic in your application program by pulsing the remote setpoint

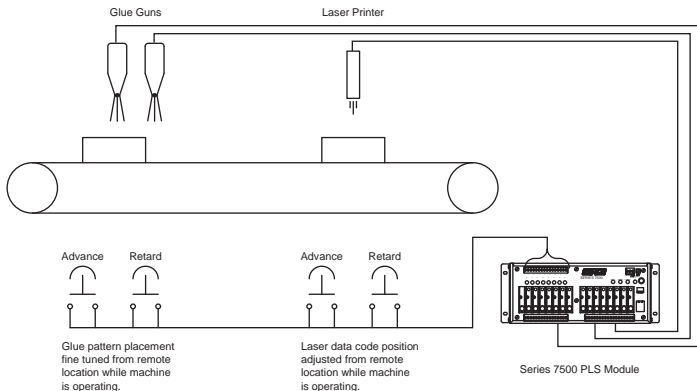

Figure 4-10 Remote Setpoint Tuning

tuning inputs either through hardware outputs tied back to the hardware inputs or by using a soft input via the network.

**Remote Position Tune (Offset)**  
Remote Position Tune (Offset) inputs can be used to advance or retard a given offset of a PLS group. Actuation of the advance/retard input will move all setpoints on all outputs within that group forward/backward in predefined (programmable) increments. Operators can watch these changes and make small adjustments to a group of outputs while standing at the workstation where the actuators are located.

**Group Forcing**  
An input is used to force a PLS group's output to a specified state regardless of the resolver/encoder position and the position of the limit's settings. When the input is activated, the outputs can be forced ON, forced OFF or unforced, depending on how the input is defined. The user can also define the state the outputs are to go to when the input is deactivated.

**Output Forcing**  
This mode allows outputs to be forced ON or OFF. Any of the 16 inputs can be configured to force an output or a subset of outputs associated within a PLS group. This input acts the same as the group force input except the user can define a subset of outputs associated with a PLS group.

**Input Capture**  
The 7500 automatically captures the resolver positions when the eight hardware and eight network inputs transition. This feature records both the up and down transitions of a given input.

This position data will be captured for all inputs regardless of the function that they have been configured for, except when a specific input has not been enabled for any function. See Figure 4-11.

This feature allows the user to verify the resolver/encoder position at which Remote Setpoint Tuning, Output Enable, or Reset to Preset inputs are seen by the PLS. This can be helpful in fine tuning the placement of sensors or the timing of outputs. However, the more common use for this feature is the collection of quality control data during an assembly process. Photoelectric or other sensors can be used to verify that a product feature has been installed on a product in the correct position.



Scenario 1: Part Detected Within Programmed Window

Scenario 2: Part Not Detected Within Programmed Window

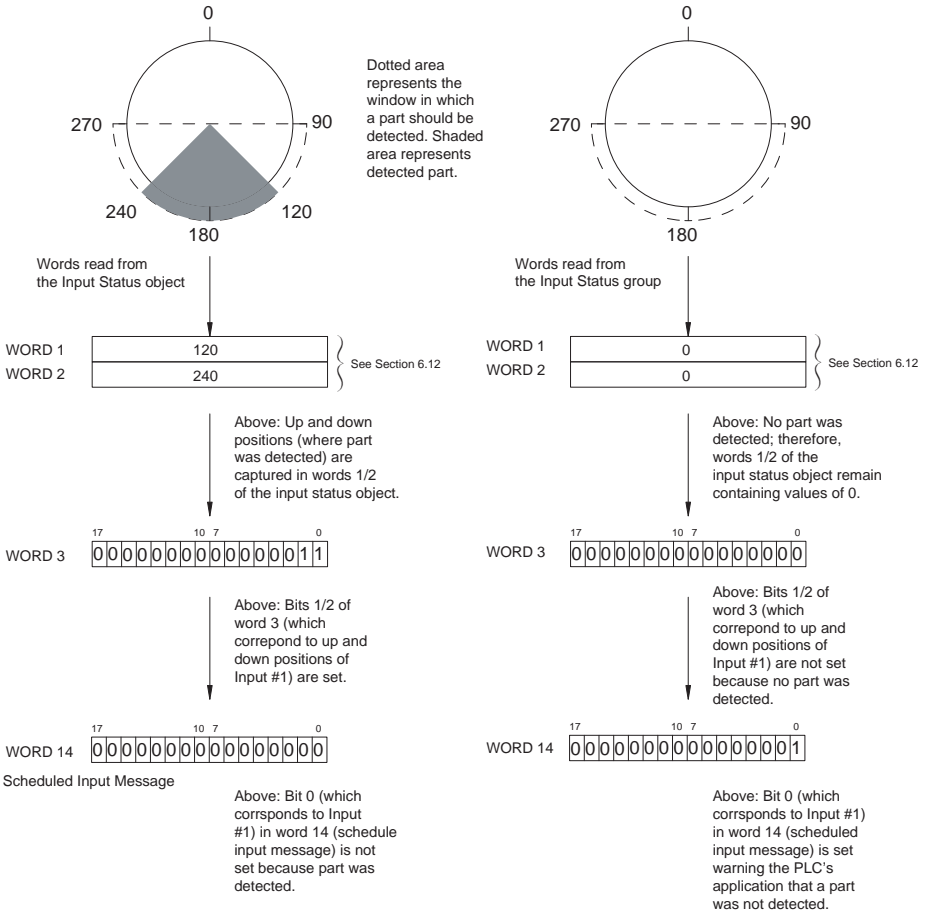

Figure 4-11 Two Scenarios Demonstrating the Input Capture Feature

## Chapter 5 Programming Basics

This chapter discusses programming basics and provides a programming outline for the 7500 UHS. Keep in mind that the outline does not provide detailed descriptions of the PLS features or programming instructions. For this information, see Chapter 4 Overview of Features and Network Programming Manual. If you are not familiar with the PLS features and would like to learn more before programming, see Chapters 4 & 6. This chapter contains information on how the PLS works. However, if you want to program the PLS now, use the outline in Section 5.2 as a guide.

Topics are discussed in the following order:

- 5.1 Things to Consider Before Programming
- 5.2 Initial Setup

Another thing to consider is before programming, is how certain commands can erase data from the PLS's running program. For example, changing the scale factor will erase setpoint data saved in the running program. Because of this the scale factor must be set before beginning to program.

### 5.1 Things to Consider Before Programming

The PLS always maintains two copies of your program. The backup copy is held in nonvolatile memory, which means that it will not be lost even when the PLS is powered down. When you make changes to the PLS's setpoint and configuration data, you are changing the running program. See Figure 5-1.

Once your changes are made, you should always save them by using the Save command (see Network Programming Manual for details). The Save command copies the running program into the backup copy. If you forget to save your changes, they will be lost if the PLS loses power.

If you make changes to the running program and decide you do not want to keep those changes, you can undo them by using the Restore command. See Section 6.11. This command copies the backup copy back into the running program. All transfers are handled seamlessly from the running program to the nonvolatile memory and back again.

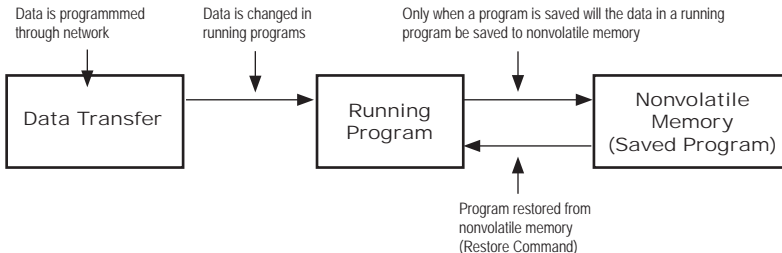

Figure 5-1 Relationship Between Running Program and Saved Program

## 5.2 Initial Setup

This section provides a sequence of steps that need to be taken in order to program the PLS properly. Keep in mind that this is only an outline and does not provide detailed explanations on how the PLS features work or detailed programming instructions. This information can be found in Chapter 4 Overview of Features and Chapter 6 ControlNet Network Programming section for details. Following are the steps to program the PLS:

### Step 1 System Initialization

System initialization establishes all default values in the memory. It is good standard practice to reinitialize any module being used for the first time in a new system. This will clear all unwanted data in the memory and will reestablish all factory default values, preventing unwanted data from interfering with the operation of your new application program. This should only be performed one time per installation.

**NOTE:** Due to the interaction of certain programmed features and programming sequences, initial setup should be performed in the sequence noted. If a listed feature is not being used in your application, proceed to the next step. Note that the listed sequence includes data that appears in a common group.

### Step 2 Group Configuration

#### 2a Selection of Scale Factor for Each Group

The scale factor can be programmed to whichever engineering units are appropriate for the application. For example, one rotation of the resolver

could represent one product moving through the machine. The length of the product could then be programmed as the scale factor and setpoints can then be programmed in length units that represent where they occur along the product. Valid scale factors can be from 2 to 65,535. Setting the scale factor erases any existing setpoint data.

#### 2b Select Outputs for Each Group

Grouping is an easy way to tie together multiple outputs that are controlled in the exact same manner or associated with the same aspect of a process. These parameters set up which outputs are in the group, the scale factor of the group, the input operating mode for the group, (multiple inputs can be configured for a group and can be configured to only effect certain outputs in a group), and the group offset. Groups can be comprised of both hardware outputs (1-16) and software outputs (17-32). Outputs assigned to a group do not have to be consecutive. For example, outputs 1, 7 and 11 can be a group.

#### 2c Select Inputs for Each Group

The feature is used so multiple inputs can be tied to a group. Each input can control all outputs in a group or only specified outputs.

#### 2d Minimum Speed Disable

This feature allows selected limit switch output channels to be automatically turned OFF if the machine speed drops below a programmed RPM value. It can also be used to prevent output channels from turning ON until a desired operating speed is reached. Typical uses include turning off glue guns or retracting actuators to a safe position under emergency stop conditions.

### Step 3 Synchronization with Machine (Home or Offset)

After programming the scale factor, you can then synchronize the resolver's position with the actual machine position.

### Step 4 Programming Setpoints (Standard and Stitching)

Setpoints are the ON/OFF positions at which the limit switch outputs operate as the resolver turns through one rotation. All 32 output channels can be programmed for multiple ON/OFF dwells over each rotation of the resolver by using standard setpoint programming sequences.

### Step 5 Motion Detect Output

Any one of the 32 limit switch output channels can be configured to operate as a motion detect output. This output will energize based upon reaching a programmed RPM value and will de-energize as RPM drops below the selected RPM value. Typical uses for this feature include latching in a machine operation when a desired operating speed is reached or for detecting a broken coupling or chain driving the resolver.

### Step 6 Stitching

The stitching setpoint was created to reduce the tedious work of inputting evenly spaced ON/OFF dwells over one rotation of the resolver. The following four steps show you how to program a stitching setpoint. These steps will greatly reduce the programming of dozens of ON/OFF dwells:

1. Select the first pattern start position on product.
2. Select the final pattern stop position on product.

3. Select number of counts over which the stitch stays ON.

4. Select number of counts over which the stitch stays OFF.

NOTE: A stitching pattern can also be used to develop an incremental output for use by an external control device like a variable frequency drive.

### Step 7 Linear Speed Offset

Linear Speed Offset automatically advances/retards limit switch outputs as machine speeds vary. This function is used to compensate for the mechanical lag in glue guns and actuators that must be precisely synchronized with the position of a product moving through a process.

### Step 8 Reset to Preset

This feature is used to synchronize groups of output channels to the product moving through a process, or to compensate for mechanical slippage or drift which may occur between the resolver and actual machine position. Any or all 16 inputs can be tied to pre-selected groups of output channels. A preset value from 0 to one less than the maximum scale factor value is then selected. Upon actuation of the input, all output channels tied to that input are reset to the preset value and begin firing their output pattern based upon continued movement from the reset point.

Most assembly or packaging applications use a sensor to detect the leading edge or registration mark on a product. This input resets a group of outputs to a preset value to perform a series of operations as the product continues through the process. All Reset to Preset inputs can be used simultaneously and will work independently to reset different groups of output channels.

### Step 9 Output Enable

Output Enable inputs are used to enable or disable selected groups of output channels based upon sensing a critical event prior to each rotation of the resolver. Typical uses of this feature include verification that a product is present at a glue station prior to allowing the glue guns to operate. Any or all inputs can be programmed to enable or disable selected groups of output channels based on sensing the enable input prior to the start of the output pattern. All Output Enable inputs can be used simultaneously and will work independently to enable different groups of output channels.

### Step 10 Remote Setpoint Tuning

Any or all inputs can be used to advance or retard a group of output channels from a remote location. Actuation of the advanced or retard input will move all setpoints on the selected output channels forward or backward by a programmable number. Operators can make count adjustments to the outputs while standing at the workstation.

### Step 11 Input Capturing

The Input Capture feature is used to detect the resolver position at which the eight front panel inputs and eight Network inputs occur. This feature can be helpful for fine tuning the location and timing of photoelectric or proximity sensors that provide inputs to the PLS module. It can also be used to verify the presence or completion of critical assembly processes for quality control purposes. For example, if bottles are being capped, one of the inputs can be used to verify that each bottle cap is present as it passes a sensing device. If the cap is not detected, the PLS will warn the PLC's application program that a bottle was not capped.

### Advanced Application Features

- The five microsecond update time of the 16 ultra high-speed limit switch outputs will allow the use of these output channels as incremental outputs of resolver velocity or position. The extended setpoint programming sequence (described in the Network Programming Manual) can be used to start your incremental pulse train at position zero, and end at your maximum scale factor number with the desired number of pulses per revolution being programmed by mathematically calculating the appropriate on count and off count duration.
- The eight hardware inputs can be used as general purpose inputs for the PLC application program. The state of these inputs are available thru the network. The use of these unused input channels for general purpose use in your application program can eliminate the need for additional discrete input cards in the I/O chassis.

## Chapter 6 ControlNet Network Programming

This section describes how data is exchanged over the ControlNet network to the 7500 PLS. Topics are discussed in the following order:

- 6.1 ControlNet Comm Module
- 6.2 Description
- 6.3 Scheduled Message
- 6.4 Unscheduled Message
- 6.5 PLS Object  
(Class 0xC1, Attribute 1)
- 6.6 High Speed Output Object  
(Class 0xC1, Attributes 2-17)
- 6.7 Low Speed Output Object  
(Class 0xC1, Attributes 18-33)
- 6.8 Input Configuration Object  
(Class 0xC1, Attribute 34)
- 6.9 Add-On Test Object  
(Class 0xC1, Attribute 35)
- 6.10 Offset Object  
(Class 0xC1, Attribute 36)
- 6.11 Program Control Object  
(Class 0xC1, Attribute 37)
- 6.12 Encoder Object  
(Class 0xC1, Attribute 38)
- 6.13 System Info Object  
(Class 0xC0, Attribute 1)
- 6.14 Input Status Object  
(Class 0xC0, Attribute 2)
- 6.15 Offset Information Object  
(Class 0xC0, Attribute 3)
- 6.16 Configure RSLogix 5000 to Communicate with a 7500 PLS

### 6.1 ControlNet Comm Module

The 7500 UHS ControlNet module has two BNC network connections labeled

LED Number	Name	LED Pattern	Function
1	Module Status	Solid Green	Module is initialized and operating correctly
		Flashing Green	Module is waiting for initialization
		Solid Red	Major fault, module must be restarted
		Flashing Red	Minor fault, MacID has been changed after power up
2	Channel A Status	Solid Green	Channel operating correctly
		Flashing Green	Temporary errors (node will self correct) or in listen only mode
		Solid Red	Faulted unit, consult factory
		Flashing Red	Incorrect node configuration, duplicate MacID, or channel disconnected from Network
3	Channel B Status	Solid Green	Channel operating correctly
		Flashing Green	Temporary errors (node will self correct) or in listen only mode
		Solid Red	Faulted unit, consult factory
		Flashing Red	Incorrect node configuration, duplicate MacID, or channel disconnected from Network
4	Module Owned	Solid Green	Network card is communicating with the 7500 UHS
		Steady OFF	Network card is not communicating

A and B, four network status LEDs and a network access port labeled NAP. The ControlNet module has two rotary switches used to set the module's MacID address on the network. Any address from 0 to 99 can be selected. Note, changing the node address only takes effect on power up. Changing the MacID with power applied to the unit will generate a minor fault.

The ControlNet module is equipped with four bi-color status and indication LEDs. During the start up of the 7500, the Module Status and Module Owned LEDs are lit for one second to indicate that they are working properly. After that they will be lit as specified below. After the ControlNet module is initialized, the Network LEDs will flash red/green for one second, indicating a self test of the network chip. For LED numbers, see Figure 6-1.

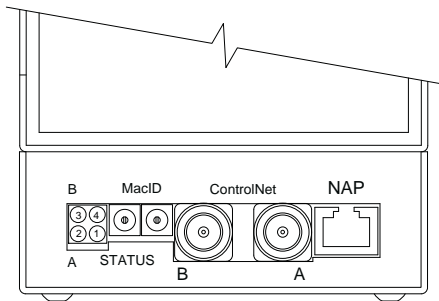

Figure 6-1 LED

## 6.2 Description

Data is communicated over ControlNet using two types of messaging:

- Scheduled Messages
- Unscheduled Messages

Scheduled messages are used for time critical data such as position and output status. Unscheduled messages are used for configuration data such as scale factor and setpoint programming.

## 6.3 Scheduled Messages

There are two types of schedule messages. The scheduled input message contains time critical data received from the 7500 such as position data and output status. The scheduled output message contains time critical data sent to the 7500 such as force registers and enabling/disabling of outputs.

**NOTE: WORD 0 and 1 are reserved for communications.**

Scaled Position - WORDs 2-10 of the input message contain the scaled position of each PLS group.

RPM - WORD 11 contains the current RPM value of the resolver.

Resolver Fault Data - WORD 12 contains the resolver fault data:

- 0 - no resolver fault
- 1 - resolver fault detected

Output Status - WORDs 13 and 14 contain the current status of the outputs. These are bit registers with Output 1 at Bit 0 of WORD 11 and Output 17 at Bit 0 of WORD 14.

Input Status - WORD 15 contains the current status of the eight hardware inputs with Input 1 at Bit 0 and Input 8 at Bit 7.

Input Warning Map - WORD 16 contains the input warning map for all 16 inputs. Input 1 is assigned to Bit 0 and Input 16 is assigned to Bit 15. If an input is

WORD	Data	Description	Type
WORD 0	Reserved	Reserved	UINT
WORD 1	Reserved	Reserved	UINT
WORD 3	Resolver Data	Group 1 Scaled Position	UINT
WORD 4		Group 2 Scaled Position	UINT
WORD 5		Group 3 Scaled Position	UINT
WORD 6		Group 4 Scaled Position	UINT
WORD 7		Group 5 Scaled Position	UINT
WORD 8		Group 6 Scaled Position	UINT
WORD 9		Group 7 Scaled Position	UINT
WORD 10		Group 8 Scaled Position	UINT
WORD 11		RPM Value	UINT
WORD 12		Resolver Fault Data	UINT
WORD 13	Output Data	Output Status (1-16)	UINT
WORD 14		Output Status (17-32)	UINT
WORD 15	Input Data	Input Status (1-16)	UINT
WORD 16		Input Warning Map	UINT
WORD 17	Config Data	Configuration Error Code	UINT
WORD 18		Error Attribute Number	UINT
WORD 19		Error WORD Number	UINT

defined as an output enable window and there was no input detected within the window, the corresponding bit for that input will be set to a 1.

Configuration Error Code, Error Attribute Number, and Error Word Number - When an unscheduled message is received, the data is verified by the 7500. If there is an error in any of the data, it will be reflected in the configuration error code.

The Error Attribute Number contains the attribute number the error was found in and the Error Word Number contains the word number that had the invalid data.

Error Codes	
0	No Error Detected
1	Invalid Data Value
2	Conflict In Data Values
3	Could Not Process Because Of Resolver Error
4	Memory Error

These error codes will be described in detail in the unscheduled message section.

### Scheduled Output Message

The following table contains data for the scheduled output message:

WORD	Data	Description	Type
WORD 1	Bit Register		UINT
	Bit 0	Run Enable Bit	
	Bit 1	Add-On Test Enable Bit	
	Bit 2	Acknowledge Bit	
WORD 2	Force Data	Force Output Mask 1-8	UINT
WORD 3		Force Output Mask 9-16	UINT
WORD 4		Force Output Mask 17-24	UINT
WORD 5		Force Output Mask 25-32	UINT
WORD 6		Force Group Mask 1-8	UINT
WORD 7	Input Data	Soft Input States (9-16)	UINT

Run Enable Bit - This bit will enable and disable the outputs on the 7500. When this bit is set, the outputs will operate normally. When this bit is cleared, the outputs will be disabled.



**Add-On Test Enable Bit** - This bit will enable the Add-On Test mode on the 7500. When a transition from 0 to 1 is detected, the Add-On Test will enable the specified outputs to run at the specified RPM value for the specified time. These values are set through the Add-On Test Object.

**Acknowledge Bit** - This bit is used to acknowledge the configuration error code in the scheduled input message. When a transition from 0 to 1 is detected, the configuration error code field, along with the error attribute number and the error word number, will be cleared.

**Force Data** - The force output masks are used to force an output ON or OFF. Each output is represented by two bits in the register as shown below.

Output 8		Output 7		Output 6		Output 5	
15	14	13	12	11	10	9	8

Output 4		Output 3		Output 2		Output 1	
7	6	5	4	3	2	1	0

Error Codes	
00	Unforce Output
01	Force Output ON
10	Force Output OFF
11	Reserved

WORD 6 is used to force all the outputs of an entire group ON or OFF. The group force mask will override the individual force masks.

**Input Data** - WORD 7 indicates the current state of the software inputs. If the input is designated as active high, a transition from 0 to 1 will trigger the input. If the input is designated as active low, a

transition from 1 to 0 will trigger the input.

## 6.4 Unscheduled Messages

Configuration data is transferred to the 7500 PLS through unscheduled messages. The 7500 PLS uses the Parameter Input Class 0xC0 (hex) and the Parameter Output Class 0xC1 (hex) to accomplish this. The Parameter Input Class has three attributes.

Attribute Number	Attribute Name
1	System Information
2	Input Status Information
3	Offset Information

The Parameter Output Class has 38 attributes. They are listed in the following table.

Attribute Number	Attribute Name
1	PLS Object
2	High Speed Output Object - Output 1
3	High Speed Output Object - Output 2
4	High Speed Output Object - Output 3
5	High Speed Output Object - Output 4
6	High Speed Output Object - Output 5
7	High Speed Output Object - Output 6
8	High Speed Output Object - Output 7
9	High Speed Output Object - Output 8
10	High Speed Output Object - Output 9
11	High Speed Output Object - Output 10
12	High Speed Output Object - Output 11
13	High Speed Output Object - Output 12
14	High Speed Output Object - Output 13
15	High Speed Output Object - Output 14
16	High Speed Output Object - Output 15
17	High Speed Output Object - Output 16
18	High Speed Output Object - Output 17
19	High Speed Output Object - Output 18
20	High Speed Output Object - Output 19
21	High Speed Output Object - Output 20
22	High Speed Output Object - Output 21
23	High Speed Output Object - Output 22
24	High Speed Output Object - Output 23
25	High Speed Output Object - Output 24
26	High Speed Output Object - Output 25
27	High Speed Output Object - Output 26
28	High Speed Output Object - Output 27
29	High Speed Output Object - Output 28
30	High Speed Output Object - Output 29
31	High Speed Output Object - Output 30
32	High Speed Output Object - Output 31
33	High Speed Output Object - Output 32
34	Input Configuration Object
35	Add-On Test Configuration Object
36	Offset Configuration Object
37	Program Control Object
38	Encoder Object

The following sections will describe each object in detail.

## 6.5 PLS Object (Class 0xC1, Attribute 1)

The PLS Object contains the configuration data for each group in the PLS. This object should be the first one programmed into the 7500 before any other data. Each PLS Object contains the following information:

WORD	Data	Description	Type
WORD 1	PLS Data 1	Scale Factor	UINT
WORD 2		High Speed Output Mask	UINT
WORD 3		Low Speed Output Mask	UINT
WORD 4		Input Mask	UINT
WORD 5		Min. Speed Disable	UINT
WORD 6		Min. Speed Disable Mask	UINT
WORD 7	PLS Data 2	Scale Factor	UINT
WORD 8		High Speed Output Mask	UINT
WORD 9		Low Speed Output Mask	UINT
WORD 10		Input Mask	UINT
WORD 11		Min. Speed Disable	UINT
WORD 12		Min. Speed Disable Mask	UINT
WORD 13	PLS Data 3	Scale Factor	UINT
WORD 14		High Speed Output Mask	UINT
WORD 15		Low Speed Output Mask	UINT
WORD 16		Input Mask	UINT
WORD 17		Min. Speed Disable	UINT
WORD 18		Min. Speed Disable Mask	UINT
WORD 19	PLS Data 4	Scale Factor	UINT
WORD 20		High Speed Output Mask	UINT
WORD 21		Low Speed Output Mask	UINT
WORD 22		Input Mask	UINT
WORD 23		Min. Speed Disable	UINT
WORD 24		Min. Speed Disable Mask	UINT

WORD 25	PLS Data 5	Scale Factor	UINT
WORD 26		High Speed Output Mask	UINT
WORD 27		Low Speed Output Mask	UINT
WORD 28		Input Mask	UINT
WORD 29		Min. Speed Disable	UINT
WORD 30		Min. Speed Disable Mask	UINT
WORD 31	PLS Data 6	Scale Factor	UINT
WORD 32		High Speed Output Mask	UINT
WORD 33		Low Speed Output Mask	UINT
WORD 34		Input Mask	UINT
WORD 35		Min. Speed Disable	UINT
WORD 36		Min. Speed Disable Mask	UINT
WORD 37	PLS Data 7	Scale Factor	UINT
WORD 38		High Speed Output Mask	UINT
WORD 39		Low Speed Output Mask	UINT
WORD 40		Input Mask	UINT
WORD 41		Min. Speed Disable	UINT
WORD 42		Min. Speed Disable Mask	UINT
WORD 43	PLS Data 8	Scale Factor	UINT
WORD 44		High Speed Output Mask	UINT
WORD 45		Low Speed Output Mask	UINT
WORD 46		Input Mask	UINT
WORD 47		Min. Speed Disable	UINT
WORD 48		Min. Speed Disable Mask	UINT

**Scale Factor** - This word is used to program the scale factor for each group. Valid scale factor values range from 2 to 65,535.

An invalid scale factor will produce an Invalid Data Value Code (1) in the configuration error word of the scheduled input message along with a value of 1 in the error attribute number and the word number that contains the invalid scale factor value.

**High Speed Output Mask** - This word defines which of the high speed outputs (1-16) are assigned to the group. Each bit in the word represents an output with Bit 0 assigned to Output 1 and Bit 15 assigned to Output 16. When the bit is set, the output will be assigned to the group.

An output cannot be assigned to multiple groups. If an attempt is made to do this, a Conflict In Data Code (2) will appear in the configuration error word along with a value of 1 in the error attribute number and the word number that contains the conflicting high speed output mask.

**Low Speed Output Mask** - This word defines which of the low speed outputs (17-32) are assigned to the group. Each bit in the word represents an output with Bit 0 assigned to Output 17 and Bit 15 assigned to Output 32. When the bit is set, the output will be assigned to the group.

An output cannot be assigned to multiple groups. If an attempt is made to do this, a Conflict In Data Code (2) will appear in the configuration error word along with a value of 1 in the error attribute number

and the word number that contains the conflicting low speed output mask.

**Input Mask** - This word defines which of the inputs are assigned to the group. Each bit in the word represents an input with Bit 0 assigned to Input 1 and Bit 15 assigned to Input 16. When the bit is set, the input will be assigned to the group.

An input cannot be assigned to multiple groups. If an attempt is made to do this, a Conflict In Data Code (2) will appear in the configuration error word along with a value of 1 in the error attribute number and the word number that contains the conflicting input mask.

**Minimum Speed Disable** - This word contains the RPM value for the minimum speed disable feature. Valid minimum speed values range from 0 to 2048. A value of zero will disable this feature.

An invalid minimum speed disable value will produce an Invalid Data Value Code (1) in the configuration error word of the scheduled input message along with a value of 1 in the error attribute number and the word number that contains the invalid minimum speed disable value.

**Minimum Speed Disable Mask** - This word defines which outputs in the group are affected by the minimum speed disable value. Each bit in the word represents an output with Bit 0 assigned to Output 1 and Bit 15 assigned to Output 16.

The output must be assigned to the group in order to be part of the minimum speed disable mask. If an output is assigned to the minimum speed disable

mask and it is not assigned to the group, an Invalid Data Value Code (1) will appear in the configuration error word along with a value of 1 in the error attribute number and the word number that contains the invalid minimum speed disable mask.

## 6.6 High Speed Output Object (Class 0xC1, Attributes 2-17)

Each high speed output has a High Speed Output Attribute associated with it. This attribute contains the linear speed compensation data and the setpoint data for the output.

The linear speed compensation is calculated using a minimum RPM, or starting point, and a maximum RPM, or stopping point. The starting point consists of the RPM value that the linear speed compensation will begin with and the starting on counts and off counts the setpoints are to be shifted by. The stopping point consists of the RPM value that the linear speed compensation will stop at and the ending on counts and off counts the setpoints are to be shifted by.

Each output can be programmed as a standard output, a time based output, or a motion control output. This is done through first setpoint definition. If the output is defined as a time based output or a motion control output, no other setpoints can be programmed. If the output is defined as a standard output, the first setpoint can be a standard setpoint or a stitching setpoint. The other seven setpoints are standard setpoints.

WORD	Data	Description	Type
WORD 1	Linear Speed	Linear Speed RPM Start	UINT
WORD 2		Linear Speed Start On Counts	UINT
WORD 3		Linear Speed Start Off Counts	UINT
WORD 4		Linear Speed RPM End	UINT
WORD 5		Linear Speed End On Counts	UINT
WORD 6		Linear Speed End Off Counts	UINT
WORD 7		Number of Setpoints	UINT
WORD 8	Setpoint 1	Type	UINT
WORD 9		Parameter 1	UINT
WORD 10		Parameter 2	UINT
WORD 11		Parameter 3	UINT
WORD 12		Parameter 4	UINT
WORD 13	Setpoint 2	ON Position	UINT
WORD 14		OFF Position	UINT
WORD 15	Setpoint 3	ON Position	UINT
WORD 16		OFF Position	UINT
WORD 17	Setpoint 4	ON Position	UINT
WORD 18		OFF Position	UINT
WORD 19	Setpoint 5	ON Position	UINT
WORD 20		OFF Position	UINT
WORD 21	Setpoint 6	ON Position	UINT
WORD 22		OFF Position	UINT
WORD 23	Setpoint 7	ON Position	UINT
WORD 24		OFF Position	UINT
WORD 25	Setpoint 8	ON Position	UINT
WORD 26		OFF Position	UINT

**Linear Speed RPM Start** - This word contains the RPM value that the linear speed compensation will start. Valid RPM values range from 0 to 2048.

An invalid RPM value will produce an Invalid Data Value Code (1) in the configuration error word of the scheduled input message along with the error attribute number and the word number that contains the invalid RPM value.

The RPM start value must be less than the RPM end value. If the RPM start value is greater than the stop value, a Conflict in Data Code (2) will appear in the configuration error word of the scheduled input message along with the error attribute number and the word number that contains the invalid RPM value.

**Linear Speed Start On Counts** - This word contains the count value that the leading edge of the setpoint will be shifted by at the start RPM value.

The linear speed start on counts must be less than the linear speed end on counts. If the start on counts are greater than the end on counts, a Conflict in Data Code (2) will appear in the configuration error word of the scheduled input message along with the error attribute number and the word number that contains the invalid start on counts.

**Linear Speed Start Off Counts** - This word contains the count value that the trailing edge of the setpoint will be shifted by at the start RPM value.

The linear speed start off counts must be less than the linear speed end off counts.

If the start off counts are greater than the end off counts, a Conflict in Data Code (2) will appear in the configuration error word of the scheduled input message along with the error attribute number and the word number that contains the invalid start off counts.

**Linear Speed RPM End** - This word contains the RPM value at which the linear speed compensation will end. Value RPM values range from 0 to 2048.

An invalid RPM value will produce an Invalid Data Value Code (1) in the configuration error word of the scheduled input message along with the error attribute number and the word number that contains the invalid RPM value.

The RPM end value must be greater than the RPM start value. If the RPM end value is less than the start value, a Conflict in Data Code (2) will appear in the configuration error word of the scheduled input message along with the error attribute number and the word number that contains the invalid RPM value.

**Linear Speed End On Counts** - This word contains the count value at which the leading edge of the setpoint will be shifted by at the end RPM value.

The linear speed end on counts must be greater than the linear speed start on counts. If the end on counts are less than the start on counts, a Conflict in Data Code (2) will appear in the configuration error word of the scheduled input message along with the error attribute number and the word number that contains the invalid end on counts.

Linear Speed End Off Counts - This word contains the count value that the trailing edge of the setpoint will be shifted by at the end RPM value.

The linear speed end off counts must be greater than the linear speed start off counts. If the end off counts are less than the start off counts, a Conflict in Data Code (2) will appear in the configuration error word of the scheduled input message along with the error attribute number and the word number that contains the invalid end off counts.

NOTE: If all the above parameters are set to zero, there will be no linear speed compensation performed on the output.

Number of Setpoints Pairs - This word contains the number of setpoints pairs that are to be programmed for this output. This number can range from zero to eight. This number is used to determine which setpoints in the attribute to look at.

For example, if the number of setpoints is 5, the 7500 will only process the data located in setpoints 1-5 of the attribute. The data in setpoints 6-8 is ignored.

An Invalid Data Value Code (1) will be produced in the configuration error word of the scheduled input message along with the attribute number and the word number if the number of setpoints pairs is greater than eight.

Setpoint 1 Type - This word contains the setpoint type for the first setpoint. There are four types of setpoints:

- 1 - Standard Setpoints
- 2 - Stitching Setpoints
- 3 - Time Based Setpoints
- 4 - Motion Detect Setpoints

A value of 0 in the setpoint type indicates no setpoint programmed.

Parameters 1, 2, 3, 4 - The values in these words depend on the setpoint type chosen in the Setpoint 1 Type word. The table below shows which values are stored in each parameter.

Setpoint On Position - This word contains the position value at which the setpoint will activate. Valid positions range from zero to a value one less than the scale factor.

Input Type	Parameter 1	Parameter 2	Parameter 3	Parameter 4
Standard Setpoint	ON Position	OFF Position	--	--
Stitching Setpoint	ON Position	OFF Position	Counts High	Counts Low
Time Based Setpoint	ON Position	Time in ms	--	--
Motion Detect	RPM Value	--	--	--

An invalid position value will produce an Invalid Data Value Code (1) in the configuration error word of the scheduled input message along with the attribute number and the word number containing the invalid on position.

**Setpoint Off Position** - This word contains the position where the setpoint will deactivate.

Valid positions range from zero to a value one less than the scale factor.

An invalid position value will produce an Invalid Data Value Code (1) in the configuration error word of the scheduled input message along with the attribute number and the word number containing the invalid OFF position.

**Counts High** - In a stitching setpoint, this is the stitch count at which the setpoint will be activated.

**Counts Low** - In a stitching setpoint, this is the stitch count at which the setpoint will be deactivated.

**Time in ms** - For time based setpoints, this is the time in milliseconds at which the setpoint will remain on.

## 6.7 Low Speed Output Object (Class 0xC1, Attributes 18-33)

Each low speed output (17-32) has a Low Speed Output Attribute associated with it. This attribute contains the setpoint data for the output.

Each output can be programmed as a standard output, a time based output, or a motion control output. This is done

through first setpoint definition. If the output is defined as a time based output or a motion control output, no other setpoints can be programmed. If the output is defined as a standard output, the first setpoint can be a standard setpoint or a stitching setpoint. The other seven setpoints are standard setpoints. Outputs 17-32 cannot be programmed for linear speed compensation.

WORD	Data	Description	Type
WORD 1		Number of Setpoints	UINT
WORD 2	Setpoint 1	Type	UINT
WORD 3		Parameter 1	UINT
WORD 4		Parameter 2	UINT
WORD 5		Parameter 3	UINT
WORD 6		Parameter 4	UINT
WORD 7	Setpoint 2	ON Position	UINT
WORD 8		OFF Position	UINT
WORD 9	Setpoint 3	ON Position	UINT
WORD 10		OFF Position	UINT
WORD 11	Setpoint 4	ON Position	UINT
WORD 12		OFF Position	UINT
WORD 13	Setpoint 5	ON Position	UINT
WORD 14		OFF Position	UINT
WORD 15	Setpoint 6	ON Position	UINT
WORD 16		OFF Position	UINT
WORD 17	Setpoint 7	ON Position	UINT
WORD 18		OFF Position	UINT
WORD 19	Setpoint 8	ON Position	UINT
WORD 20		OFF Position	UINT

**Number of Setpoints** - This word contains the number of setpoint pairs that are to be programmed for this output. This number can range from zero to eight. This number is used to determine which setpoints in the attribute to look at. For example, if the number of setpoints pairs is five, the 7500 will only process the data located in setpoints 1-5 of the attribute. The data in setpoints 6-8 are ignored.

An Invalid Data Value Code (1) will be produced in the configuration error word



of the scheduled input message along with the attribute number and the word number if the number of setpoints is greater than eight.

Setpoint 1 Type - This word contains the setpoint type for the first setpoint. There are four types of setpoints:

- 1 - Standard Setpoints
- 2 - Stitching Setpoints
- 3 - Time Based Setpoints
- 4 - Motion Detect Setpoints

A value of 0 in the setpoint type indicates that no setpoint is programmed.

Parameters 1, 2, 3, 4 - The values in these words depend on the setpoint type used for the Setpoint 1 Type word. The table below shows which values are stored in each parameter.

Setpoint ON Position - This word contains the position value at which the setpoint will activate. Valid positions range from zero to a value one less than the scale factor.

An invalid position value will produce an Invalid Data Value Code (1) in the configuration error word of the scheduled

input message along with the attribute number and the word number containing the invalid ON position.

Setpoint OFF Position - This word contains the position value at which the setpoint will deactivate. Valid positions range from zero to a value one less than the scale factor.

An invalid position value will produce an Invalid Data Value Code (1) in the configuration error word of the scheduled input message along with the attribute number and the word number containing the invalid OFF position.

High Stitch Count - In a stitching setpoint, this is the stitch count at which the setpoint will be activated.

Low Stitch Count - In a stitching setpoint, this is the stitch count at which the setpoint will be deactivated.

Time in ms - This is the time in milliseconds that the setpoint will remain on.

Input Type	Parameter 1	Parameter 2	Parameter 3	Parameter 4
Standard Setpoint	ON Position	OFF Position	--	--
Stitching Setpoint	ON Position	OFF Position	High Stitch Count	Low Stitch Count
Time Based Setpoint	ON Position	Time in ms	--	--
Motion Detect	RPM Value	--	--	--

## 6.8 Input Configuration Object (Class 0xC1, Attribute 34)

The Input Configuration Object is used to define the functionality of each input and define the parameters associated with that function.

There are 18 types of functions that can be assigned to an input.

- Remote Setpoint Tune
- Reset to Preset (Standard)
- Reset to Preset (Single Shot)
- Reset to Preset (Average)
- Reset to Preset (Window)
- Output Enable (Level)
- Output Enable (Single Shot)
- Output Enable (Advanced)
- Output Force
- Remote Offset Tune
- Reset to Preset Group (Standard)
- Reset to Preset Group (Single Shot)
- Reset to Preset Group (Average)
- Reset to Preset Group (Window)
- Output Enable Group (Level)
- Output Enable Group (Single Shot)
- Output Enable Group (Advanced)
- Force Group

**Remote Setpoint Tune** - This input type is used to advance or retard a given group of setpoints by a specified amount of counts.

**Reset to Preset (Standard)** - This input type is used to reset the position of a PLS group to a preset value. If the output mask of the input is a subset of the outputs in the PLS group, only the outputs associated with the input will be reset. The outputs will then fire according to the new preset position until another input occurs.

**Reset to Preset (Single Shot)** - This input type is used to reset the position of a PLS group to a preset value and fire the outputs for one revolution of the resolver. If no other input is seen within that revolution, the outputs will be forced OFF until another input is detected. If the output mask of the input is a subset of the outputs in the PLS group, only the outputs associated with the input will be reset.

**Reset to Preset (Average)** - This input type is used to reset the position of a PLS group to an average position value. When the input is detected, the current position is recorded and added to the list of past input positions. This list can range in size from 1 to 32. The list of positions are averaged together to become the 'preset' value that the outputs will operate from.

**Reset to Preset (Window)** - This input acts as a Reset to Preset (Single Shot) with the exception that the user can program a specific window for the input to be detected in. If an input is detected outside the window, the Reset to Preset input will be ignored.

**Output Enable (Level)** - This input type acts as a simple AND input. When the input is activated, the outputs associated with the input will fire. When the input is deactivated, the outputs will be forced OFF.

**Output Enable (Single Shot)** - For this input type, the user must program a window in which the input will fire. When the input fires in the window, the outputs associated with the input will be enabled. When the input is detected it is enabled until the beginning of the window. If the

input fires outside the window or doesn't fire at all, the outputs will be forced OFF.

**Output Enable (Advanced)** - This input type is similar to Output Enable (Single Shot). The user must program a window in which the input will fire. The user must also program a position value at which the outputs will be enabled for one revolution.

For example, the user has programmed the window to begin at position 100 and end at position 200. The enable position value is set at 150. If the input is detected at position 120, the outputs will not be enabled until position 150 and then they will stay enabled for one full revolution of the resolver.

**Output Force** - This input acts the same as the group force input except the user can define a subset of outputs associated with a PLS group.

**Remote Offset Tune** - This input type is used to advance or retard a given offset of a PLS group.

**Reset to Preset Group (Standard)** - This input type acts like the Reset to Preset (Standard) input described above except that it resets all the outputs associated with the group. The high output mask and low output mask are ignored.

**Reset to Preset Group (Single Shot)** - This input type acts just like the Reset to Preset (Single Shot) input described above except that it resets all the outputs associated with the group. The high output mask and low output mask are ignored.

**Reset to Preset Group (Average)** - This input type acts just like the Reset to Preset (Average) input described above except that it resets all the outputs associated with the group. The high output mask and low output mask are ignored.

**Reset to Preset Group (Window)** - This input type acts like the Reset to Preset (Window) input described above except that it resets all the outputs associated with the group. The high output mask and low output mask are ignored.

**Output Enable Group (Level)** - This input type acts like the Output Enable (Level) input described above except that it enables all the outputs associated with the group. The high output mask and low output mask are ignored.

**Output Enable Group (Single Shot)** - This input type acts like the Output Enable (Single Shot) input described above except that it enables all the outputs associated with the group. The high output mask and low output mask are ignored.

**Output Enable Group (Advanced)** - This input type acts just like the Output Enable (Advanced) input described above except that it will enable all the outputs associated with the group. The high output mask and low output mask are ignored.

**Force Group** - This input type is used to force a group's outputs ON or OFF. When the input is activated, the outputs can be forced ON, forced OFF or unforced depending on how the input is defined. The user can also define the state the outputs are to go to when the input is deactivated.

Word	Data	Description	Type
WORD 1	Input 1:	Bit Register	UINT
WORD 2		High Output Mask	UINT
WORD 3		Low Output Mask	UINT
WORD 4		Input Type	UINT
WORD 5		Parameter 1	UINT
WORD 6		Parameter 2	UINT
WORD 7		Parameter 3	UINT
WORD 8	Input 2:	Bit Register	UINT
WORD 9		High Output Mask	UINT
WORD 10		Low Output Mask	UINT
WORD 11		Input Type	UINT
WORD 12		Parameter 1	UINT
WORD 13		Parameter 2	UINT
WORD 14		Parameter 3	UINT
WORD 15	Input 3:	Bit Register	UINT
WORD 16		High Output Mask	UINT
WORD 17		Low Output Mask	UINT
WORD 18		Input Type	UINT
WORD 19		Parameter 1	UINT
WORD 20		Parameter 2	UINT
WORD 21		Parameter 3	UINT
WORD 22	Input 4:	Bit Register	UINT
WORD 23		High Output Mask	UINT
WORD 24		Low Output Mask	UINT
WORD 25		Input Type	UINT
WORD 26		Parameter 1	UINT
WORD 27		Parameter 2	UINT
WORD 28		Parameter 3	UINT
WORD 29	Input 5:	Bit Register	UINT
WORD 30		High Output Mask	UINT
WORD 31		Low Output Mask	UINT
WORD 32		Input Type	UINT
WORD 33		Parameter 1	UINT
WORD 34		Parameter 2	UINT
WORD 35		Parameter 3	UINT
WORD 36	Input 6:	Bit Register	UINT
WORD 37		High Output Mask	UINT
WORD 38		Low Output Mask	UINT
WORD 39		Input Type	UINT
WORD 40		Parameter 1	UINT
WORD 41		Parameter 2	UINT

WORD 42		Parameter 3	UINT
WORD 43	Input 7:	Bit Register	UINT
WORD 44		High Output Mask	UINT
WORD 45		Low Output Mask	UINT
WORD 46		Input Type	UINT
WORD 47		Parameter 1	UINT
WORD 48		Parameter 2	UINT
WORD 49		Parameter 3	UINT
WORD 50	Input 8:	Bit Register	UINT
WORD 51		High Output Mask	UINT
WORD 52		Low Output Mask	UINT
WORD 53		Input Type	UINT
WORD 54		Parameter 1	UINT
WORD 55		Parameter 2	UINT
WORD 56		Parameter 3	UINT
WORD 57	Input 9:	Bit Register	UINT
WORD 58		High Output Mask	UINT
WORD 59		Low Output Mask	UINT
WORD 60		Input Type	UINT
WORD 61		Parameter 1	UINT
WORD 62		Parameter 2	UINT
WORD 63		Parameter 3	UINT
WORD 64	Input 10:	Bit Register	UINT
WORD 65		High Output Mask	UINT
WORD 66		Low Output Mask	UINT
WORD 67		Input Type	UINT
WORD 68		Parameter 1	UINT
WORD 69		Parameter 2	UINT
WORD 70		Parameter 3	UINT
WORD 71	Input 11:	Bit Register	UINT
WORD 72		High Output Mask	UINT
WORD 73		Low Output Mask	UINT
WORD 74		Input Type	UINT
WORD 75		Parameter 1	UINT
WORD 76		Parameter 2	UINT
WORD 77		Parameter 3	UINT
WORD 78	Input 12:	Bit Register	UINT
WORD 79		High Output Mask	UINT
WORD 80		Low Output Mask	UINT
WORD 81		Input Type	UINT
WORD 82		Parameter 1	UINT

WORD 83		Parameter 2	UINT
WORD 84		Parameter 3	UINT
WORD 85	Input 13:	Bit Register	UINT
WORD 86		High Output Mask	UINT
WORD 87		Low Output Mask	UINT
WORD 88		Input Type	UINT
WORD 89		Parameter 1	UINT
WORD 90		Parameter 2	UINT
WORD 91		Parameter 3	UINT
WORD 92	Input 14:	Bit Register	UINT
WORD 93		High Output Mask	UINT
WORD 94		Low Output Mask	UINT
WORD 95		Input Type	UINT
WORD 96		Parameter 1	UINT
WORD 97		Parameter 2	UINT
WORD 98		Parameter 3	UINT
WORD 99	Input 15:	Bit Register	UINT
WORD 100		High Output Mask	UINT
WORD 101		Low Output Mask	UINT
WORD 102		Input Type	UINT
WORD 103		Parameter 1	UINT
WORD 104		Parameter 2	UINT
WORD 105		Parameter 3	UINT
WORD 106	Input 16:	Bit Register	UINT
WORD 107		High Output Mask	UINT
WORD 108		Low Output Mask	UINT
WORD 109		Input Type	UINT
WORD 110		Parameter 1	UINT
WORD 111		Parameter 2	UINT
WORD 112		Parameter 3	UINT

**Bit Register** - This word is a bit register that defines the active state of the output and the update capture value. The register is defined below

**Bit 0: Active State** - This bit defines the active state of the input. A value of zero indicates an active low state in which the input is triggered by a falling edge. A value of one indicates an active high state in which the input is triggered by a rising edge.

**Bits 1,2: Update Capture Registers** - These two bits define when the Input Capture Registers in the Input Status Attribute of the PLS Status Class (0xC0) are updated. These registers are updated in pairs. A value of zero in these bits indicates that the registers will be updated when the resolver position goes through zero. A value of one indicates that the registers will be updated when the leading edge of the input is detected. A value of two indicates that the registers will be updated when the trailing edge of the input is detected. This is defined in the table below:

Update Capture Bit Values	Description
0	Update registers through zero cross
1	Update registers at leading edge
2	Update registers at trailing edge

**High Output Mask** - This word defines which outputs are assigned to the input. Each bit in the word represents an output with bit 0 assigned to output 1 and bit 15 assigned to output 16. In order for an output to be assigned to an input, both the input and the output must belong to the same group. This word is ignored if the input type is associated with the PLS group.

**Low Output Mask** - This word defines which outputs are assigned to the input. Each bit in the word represents an output with bit 0 assigned to output 17 and bit 15 assigned to output 32. In order for an output to be assigned to an input, both the input and the output must belong to the same group. This word is ignored if the input type is associated with the PLS group.



Input Type - This word defines the input type for the specified input. The input type codes are as follows:

Parameters 1, 2, 3 - The values in these words depends on the input type. The table below defines what each parameter is based on the input type.

Input Type	Code
No Input Type	0
Remote Setpoint Tuning	10
Reset to Preset (standard)	20
Reset to Preset (single shot)	21
Reset to Preset (average)	22
Reset to Preset (window)	23
Output Enable (level)	30
Output Enable (single shot)	31
Output Enable (advanced mode)	32
Force Outputs	40
Remote Offset Tune	110
Reset to Preset Group (standard)	120
Reset to Preset Group (single shot)	121
Reset to Preset Group (average)	122
Reset to Preset Group (window)	123
Output Enable Group (level)	130
Output Enable Group (single shot)	131
Output Enable Group (advanced mode)	132
Force Group	140

Input Type	Parameter 1	Parameter 2	Parameter 3
Remote Setpoint Tune Remote Offset Tune	Counts to advance or retard	--	--
Reset to Preset (standard) Reset to Preset Group (standard)	Preset value	--	--
Reset to Preset (single-shot) Reset to Preset Group (single-shot)	Preset value	--	--
Reset to Preset (average) Reset to Preset Group (average)	Number of positions to average together	--	--
Reset to Preset (window) Reset to Preset Group (window)	Preset value	Window ON Position	Window OFF Position
Output Enable (level) Output Enable Group (level)	--	--	--
Output Enable (single-shot) Output Enable Group (single-shot)	Window ON Position	Window OFF Position	--
Force Output Force Group	Unforce, force ON, or force OFF in active state*	Unforce, force ON, or force OFF in inactive state*	--

\* This value should be a 0 to unforce the outputs, 1 to force the outputs ON, and 2 to force the outputs OFF.

## 6.9 Add-On Test Object (Class 0xC1, Attribute 35)

The Add-On Test was designed to fire the outputs as if the machine were operating at a specified RPM value. The simulated RPM and time duration is programmed into the 7500 along with the outputs that are to be operational during the test. The test is enabled by the Add-On Test enable bit in the scheduled output message. The test would run for the time duration specified and then automatically stop. If a time duration of zero is entered, the test will run until the Add-On Test enable bit is cleared.

**Simulate RPM Value** - This word contains the simulated RPM value that the test is to run at. Valid RPM values range from 10 - 2048.

**Simulate Time Value** - This word contains the time duration the test is to run in milliseconds. Values range from 0 to 65,535 ms. If the time is set to zero, the duration of the test is directly controlled by the Add-On Test enable bit in the scheduled output message.

**Simulate Output Mask** - This word defines which outputs are affected by the Add-On Test. Each bit in the word represents an output with Bit 0 assigned to Output 1 and Bit 15 assigned to Output 16.

WORD	Data	Description	Type
WORD 1	Add-On Test Parameters	Simulate RPM Value	UINT
WORD 2		Simulate Time Value	UINT
WORD 3		Simulate Output Mask	UINT

## 6.10 Offset Object (Class 0xC1, Attribute 36)

The Offset Object is used to set an offset for a PLS group. There are three different ways to set an offset for a group.

**Home Offset** - The Home Offset is used to send the position value at which the resolver is to be set. For example, if the current resolver position is at 10 and the desired position is to be at position 100, the user would send a home offset value of 100.

**Absolute Offset** - The Absolute Offset is used to set the offset value relative to the absolute resolver position. For example, the absolute resolver position is at 10 and an absolute offset of 80 is sent, the new position value would be 90.

**Relative Offset** - The Relative Offset is used to add or subtract from the current offset. For example, if the current position value is at 50 and a relative offset of -10 is sent, the new position value would be 40.

WORD	Data	Description	Type
WORD 1	Offset Bit Mask	Offset Bit Register	UINT
WORD 2	Group 1 Offset	Offset Value	INT
WORD 3	Group 2 Offset	Offset Value	INT
WORD 4	Group 3 Offset	Offset Value	INT
WORD 5	Group 4 Offset	Offset Value	INT
WORD 6	Group 5 Offset	Offset Value	INT
WORD 7	Group 6 Offset	Offset Value	INT
WORD 8	Group 7 Offset	Offset Value	INT
WORD 9	Group 8 Offset	Offset Value	INT

Offset Bit Mask - This register is used to indicate which offset values are set in the PLS groups. The register is shown below.

Group 8		Group 7		Group 6		Group 5	
15	14	13	12	11	10	9	8
Group 4		Group 3		Group 2		Group 1	
7	6	5	4	3	2	1	0

The following table contains the bit patterns to indicate which offset value is contained in the group offset word.

Bit Pattern	Offset Type
00	No Offset
01	Home Offset
10	Absolute Offset
11	Relative Offset

In order to set an offset for a group, put the appropriate offset type in the bit register and place the offset value in the group offset word.

Group Offset - The Group Offset word contains the offset value for the specified group. This value depends upon what type of offset is indicated in the bit register.

## 6.11 Program Control Object (Class 0xC1, Attribute 37)

The Program Control Object is used to initialize the 7500, save the current settings to memory (NVRAM), or restore settings from memory (NVRAM).

WORD	Data	Description	Type
WORD 1	Program Control Data	Control Code	UINT
WORD 2		Control Data	UINT

Program Control Code - This word determines which operation will be performed by the 7500. The table below contains the valid control codes.

Control Code	Program Operation
1	Initialize System
2	Save Current Settings
3	Restore Settings from NVRAM

Program Control Data - This word is reserved for future expansion.

## 6.12 Encoder Object (Class 0xC1, Attribute 38)

The Encoder Object is used to configure the type of encoder that is attached to the 7500. This attribute is valid on the 7500 encoder version only. Attempting to write to this attribute on the 7500 resolver version will produce an error.

WORD	Data	Description	Type
WORD 1	Encoder Data	Maximum Counts	UINT
WORD 2		Encoder Type	UINT

Maximum Counts - This word contains the number of pulses that are in one revolution of the encoder. This number can range from 2 to 16,384.

Encoder Type - The encoder can be configured as a X1 or X4 encoder. When this word is set to a 1, the encoder is a type X4 encoder where every edge will increment the encoder position by 1. When this word is set to 0, the encoder type is X1 where one full quadrature cycle will increment the encoder position by 1.



## 6.13 System Info Object (Class 0xC0, Attribute 1)

The System Information Object contains general information about the 7500 PLS.

WORD	Data	Description	Type
WORD 1	Software Version	Major Version Number	UINT
WORD 2		Minor Version Number	UINT

Software Version - These words contain the major and minor version number of the software that is being used in the 7500 PLS.

## 6.14 Input Status Object (Class 0xC0, Attribute 2)

The Input Status Object contains general information about the 7500 PLS.

WORD	Data	Description	Type
WORD 1	Input 1 Information	Input Leading Position	UINT
WORD 2		Input Trailing Position	UINT
WORD 3		Transition Status	UINT
WORD 4	Input 2 Information	Input Leading Position	UINT
WORD 5		Input Trailing Position	UINT
WORD 6		Transition Status	UINT
WORD 7	Input 3 Information	Input Leading Position	UINT
WORD 8		Input Trailing Position	UINT
WORD 9		Transition Status	UINT
WORD 10	Input 4 Information	Input Leading Position	UINT
WORD 11		Input Trailing Position	UINT
WORD 12		Transition Status	UINT

WORD 13	Input 5 Information	Input Leading Position	UINT
WORD 14		Input Trailing Position	UINT
WORD 15		Transition Status	UINT
WORD 16	Input 6 Information	Input Leading Position	UINT
WORD 17		Input Trailing Position	UINT
WORD 18		Transition Status	UINT
WORD 19	Input 7 Information	Input Leading Position	UINT
WORD 20		Input Trailing Position	UINT
WORD 21		Transition Status	UINT
WORD 22	Input 8 Information	Input Leading Position	UINT
WORD 23		Input Trailing Position	UINT
WORD 24		Transition Status	UINT
WORD 25	Input 9 Information	Input Leading Position	UINT
WORD 26		Input Trailing Position	UINT
WORD 27		Transition Status	UINT
WORD 28	Input 10 Information	Input Leading Position	UINT
WORD 29		Input Trailing Position	UINT
WORD 30		Transition Status	UINT
WORD 31	Input 11 Information	Input Leading Position	UINT
WORD 32		Input Trailing Position	UINT
WORD 33		Transition Status	UINT
WORD 34	Input 12 Information	Input Leading Position	UINT
WORD 35		Input Trailing Position	UINT
WORD 36		Transition Status	UINT
WORD 37	Input 13 Information	Input Leading Position	UINT
WORD 38		Input Trailing Position	UINT

WORD 39		Transition Status	UINT
WORD 40	Input 14 Information	Input Leading Position	UINT
WORD 41		Input Trailing Position	UINT
WORD 42		Transition Status	UINT
WORD 43	Input 15 Information	Input Leading Position	UINT
WORD 44		Input Trailing Position	UINT
WORD 45		Transition Status	UINT
WORD 46	Input 16 Information	Input Leading Position	UINT
WORD 47		Input Trailing Position	UINT
WORD 48		Transition Status	UINT

**Input Leading Position** - This word contains the position that the last leading edge of the input was detected.

**Input Trailing Position** - This word contains the position that the last trailing edge of the input was detected.

**Transition Status** - This word contains the current transition status of the input for this revolution. The following table contains the returned codes:

Transition Code	Transition State
0	Input not detected
1	Leading edge detected
2	Trailing edge detected
3	Leading and trailing edges detected

## 6.15 Offset Information Object (Class 0xC0, Attribute 3)

The Offset Information Object is used to retrieve the current offset values that are used for each group and input.

Group Offset Value - These words contain the current offset values that are

added to the resolver position to create the current group position.

Input Offset Value - These words contain the current offset values that are used to generate the Reset to Preset values for the inputs. If the input is not a Reset to Preset input, the value will be zero.

WORD	Data	Description	Type
WORD 1	Group Offsets	Group 1 Offset Value	UINT
WORD 2		Group 2 Offset Value	UINT
WORD 3		Group 3 Offset Value	UINT
WORD 4		Group 4 Offset Value	UINT
WORD 5		Group 5 Offset Value	UINT
WORD 6		Group 6 Offset Value	UINT
WORD 7		Group 7 Offset Value	UINT
WORD 8		Group 8 Offset Value	UINT
WORD 9	Input Offsets	Input 1 Offset Value	UINT
WORD 10		Input 2 Offset Value	UINT
WORD 11		Input 3 Offset Value	UINT
WORD 12		Input 4 Offset Value	UINT
WORD 13		Input 5 Offset Value	UINT
WORD 14		Input 6 Offset Value	UINT
WORD 15		Input 7 Offset Value	UINT
WORD 16		Input 8 Offset Value	UINT
WORD 17		Input 9 Offset Value	UINT
WORD 18		Input 10 Offset Value	UINT
WORD 19		Input 11 Offset Value	UINT
WORD 20		Input 12 Offset Value	UINT
WORD 21		Input 13 Offset Value	UINT
WORD 22		Input 14 Offset Value	UINT
WORD 23		Input 15 Offset Value	UINT
WORD 24		Input 16 Offset Value	UINT

## 6.16 Configure RSLogix 5000 to Communicate with a 7500 PLS

### Setting Up a Scheduled Message

In order to set up a scheduled message, two pieces of Allen Bradley software are required: RSNetworkx and RSLogix 5000. The following describes how to use these software packages to set up a scheduled message across the ControlNet Network.

#### RSNetworkx

Open up RSNetworkx. If this is the first time you are configuring the 7500 PLS you need to install the EDS file through the EDS wizard. This can be found under the TOOLS menu.

Go online and browse the network. The 7500 PLS will show up along with the RSLogix ControlNet bridge. Make sure you define the chassis for the ControlNet Bridge and save the file.

#### RSLogix 5000

To communicate to the 7500 PLS through RSLogix 5000, add a new module to the ControlNet bridge.

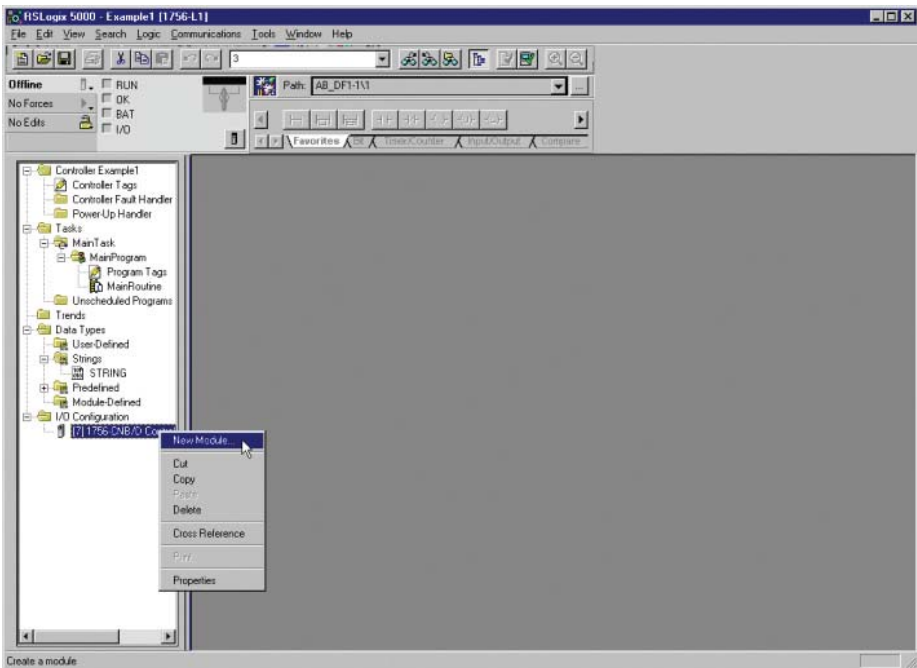

The following screen will appear:

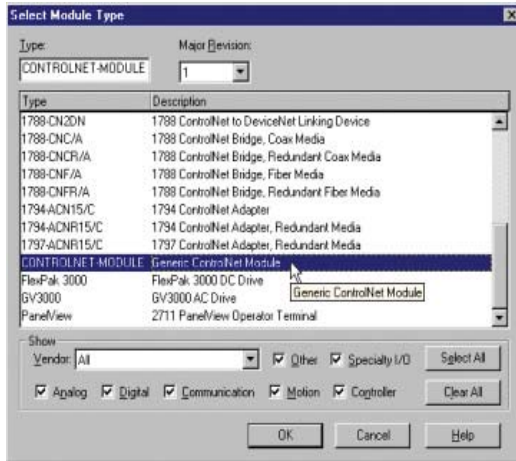

Select a Generic ControlNet Module from the list and hit OK. The Module Properties box will appear. Set the module up as follows:

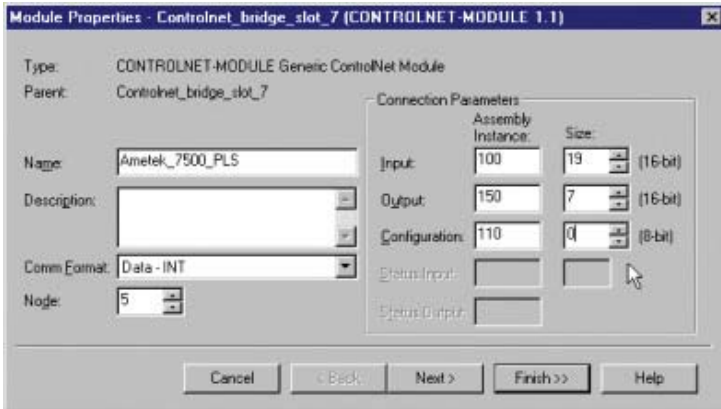

The Comm Format should be set to type Data-INT. The input assembly instance should be set to 100 with a size of 19 words. The output assembly instance should be set to 150 with a size of 7 words. The configuration assembly instance should be set to 110 with a size of 0 bytes. This will create three controller tags for the 7500 PLS. The Ametek\_7500\_PLS:I file contains the data from the scheduled input message. The Ametek\_7500\_PLS:O file contains the data for the scheduled output message. The Ametek\_7500\_PLS:C file is not used.

## Setting Up An Unscheduled Message

The following describes how to send an unscheduled message to the 7500 PLS. In the example, we will use the PLS Object.

Create a tag of type INT that is 48 words in size:

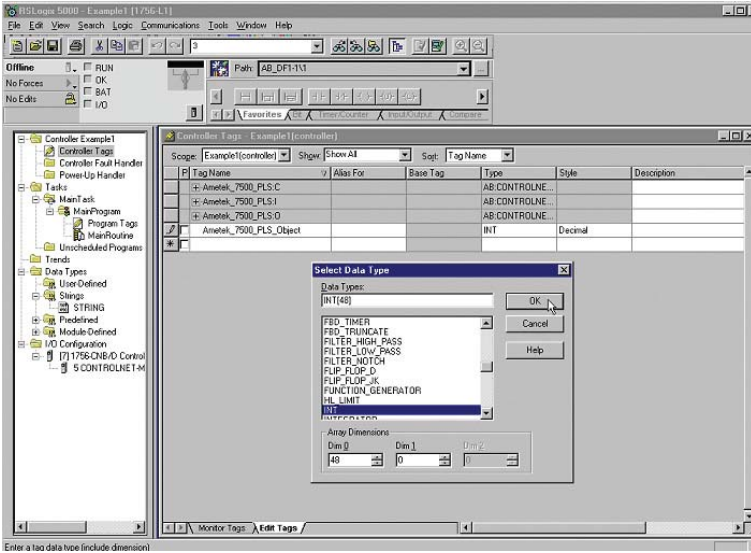

Next, create a tag of type MESSAGE. This will be used to link the PLS Object tag to the unscheduled message.

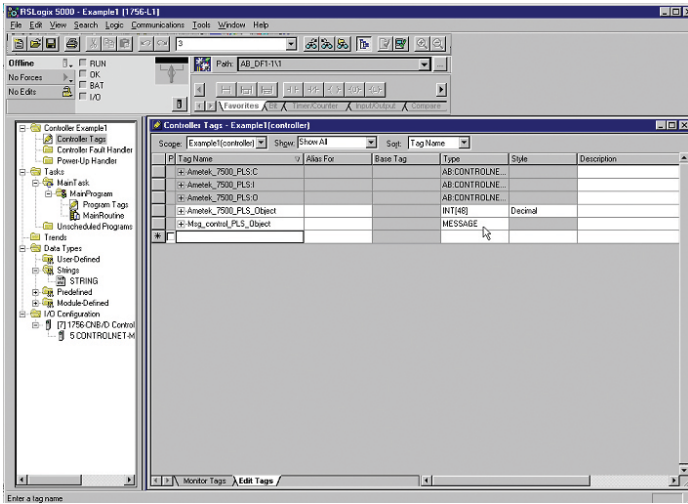

After the message tag is created, edit the tag properties of the MESSAGE tag and click on the configure button next to the data type.

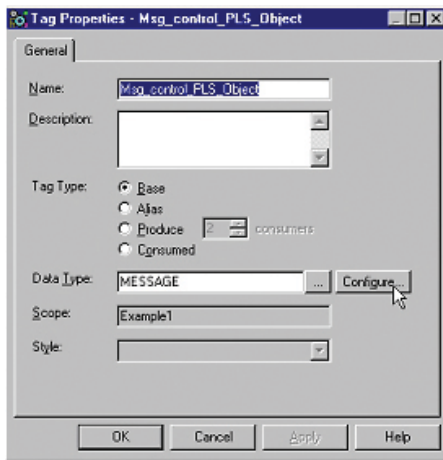

The following window will appear. Fill in the appropriate data in each field.

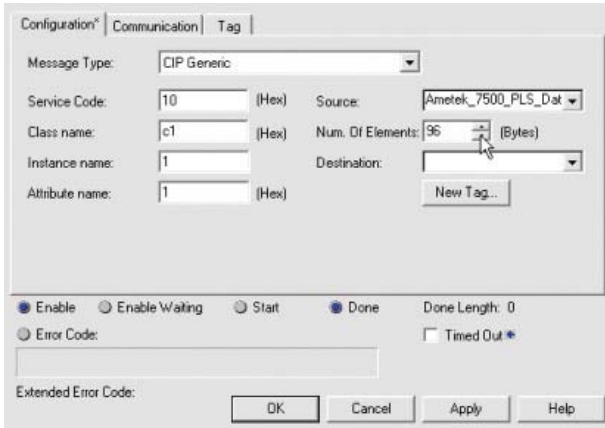

Select CIP Generic for the message type. Service code 0x10 indicates a set attribute single code.

NOTE: In order to retrieve status data, the service code would be set to 0x0E for get attribute single.

The class number is 0xC1 for the PLS configuration class. The instance number is always set to 1. The attribute number is set to 1 for the PLS Object. Click on the communication tab and select the communication path to the Ametek\_7500\_PLS.

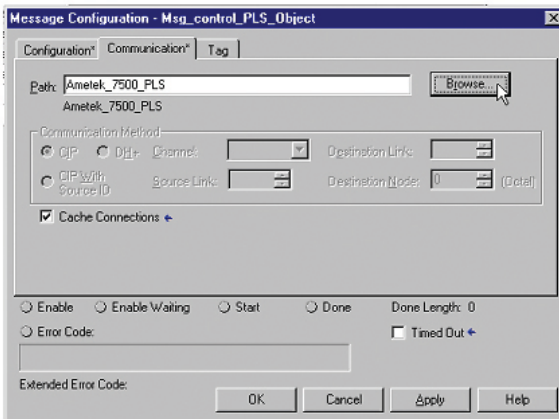

In the ladder logic add a MSG instruction and select the message control tag that was just created as its control file.



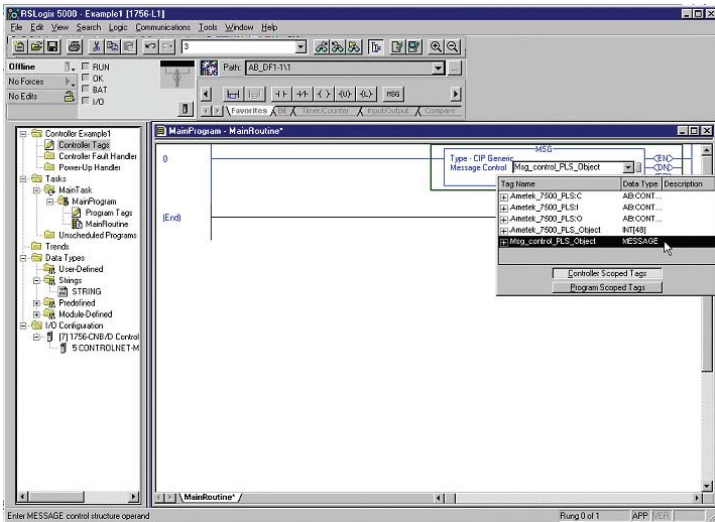

## 6.15 Configure RSLogix 500 to Communicate with a 7500 PLS

### Setting Up A Scheduled Message

In order to set up a scheduled message, two pieces of Allen Bradley software are required: RSNetworkx and RSLogix 500. The following will describe how to use these two software packages to set up a scheduled message across the ControlNet Network.

### RSNetworkx

Open up RSNetworkx. If this is the first time you are configuring the 7500 PLS you need to install the EDS file through the EDS wizard. This can be found under the TOOLS menu.

Go online and browse the network. The 7500 PLS will show up along with the PLC-5 controller.

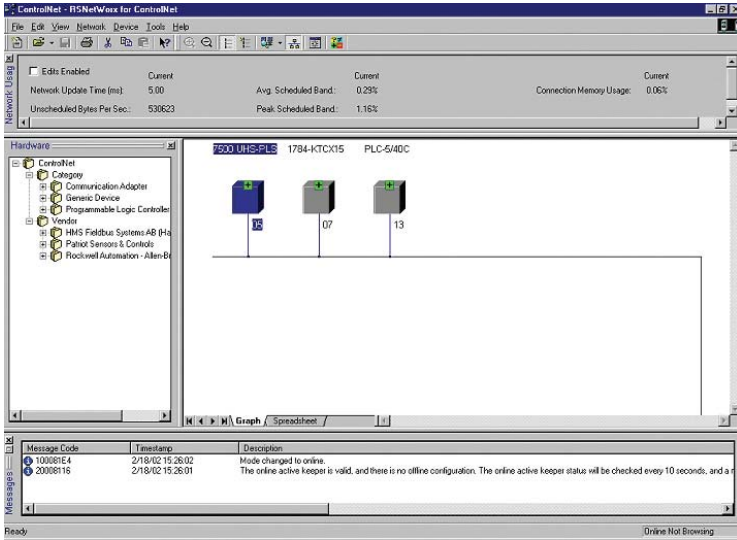

Right-click on the PLC-5 controller icon and select Scanlist Configuration. The following window will appear:

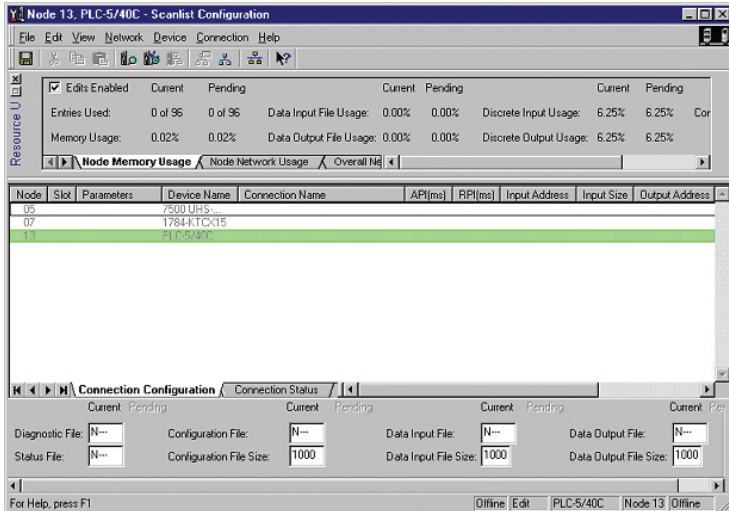

Right click on the 7500 UHS and select Insert Connection from the drop down menu. The following window will appear:

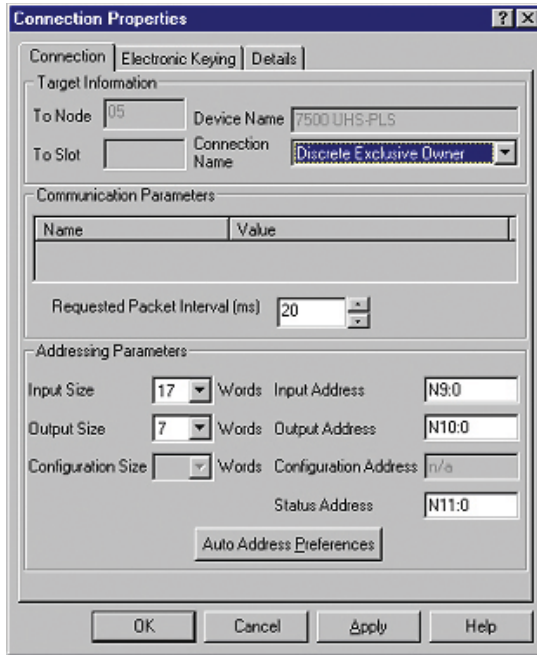

Enter 17 for the input size and select the integer file that the data is to be stored in. Enter 7 for the output size and the integer file that the data is to be retrieved from. Enter the Requested Packet Interval and hit OK.

Save the configuration. This will automatically update the keeper on the network.

RSLogix 500

Open RSLogix 500 and create a new project. The Select Process Type dialog box will appear.

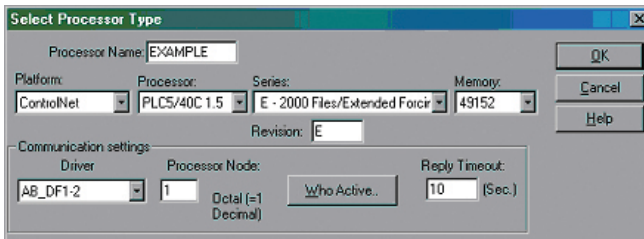

Specify the platform as ControlNet and select the correct PLC-5C processor from the list. Make sure you specify one of the PLC-5C processors that are followed by 1.5 suffix (for example, PLC-5/40C 1.5). After you have specified the processor and the connection, click OK.

The Select ControlNet Project box will appear.

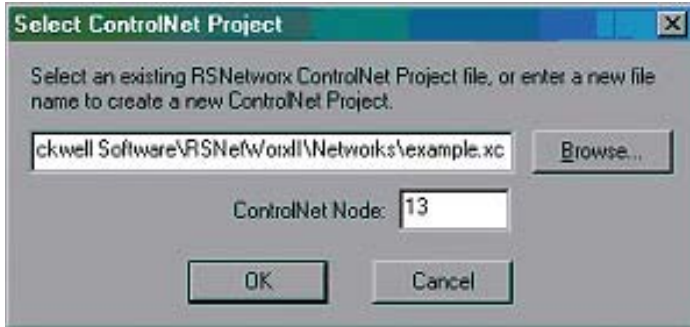

Select the ControlNet configuration file (\*.xc) that was created in the RSNetworkx and enter the node number associated with the PLC-5C processor. Click OK.

The new project will contain the integer files that were created in RSNetworkx. When the program is downloaded to the processor, the processor will send the data in the output integer file to the 7500 PLS and receive from the 7500 PLS the scheduled input data and place it in the input integer file.

### Setting Up An Unscheduled Message

The following describes how to send an unscheduled message to the 7500 PLS. In the example, we will use the PLS Object.

In the ladder logic add the ControlNet I/O Transfer instruction (CIO) to the rung.

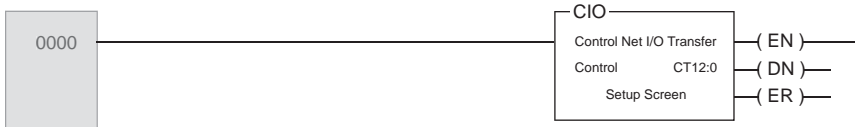

Enter the control transfer file and select Setup Screen. Fill in the window with the following data:

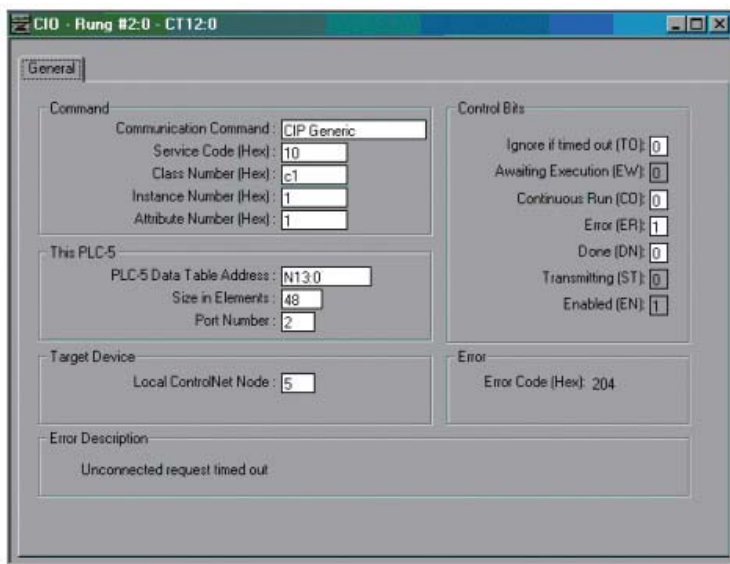

Select CIP Generic for the communication command. Service code 0x10 indicates a set attribute single code.

NOTE: in order to retrieve status data, the service code would be set to 0x0E for get attribute single.

The class number is 0xC1 for the PLS configuration class. The instance number is always set to 1. The attribute number is set to 1 for the PLS Object. Select the integer file that you wish to use. For this example, we have selected integer file N13:0. The size of the PLS Object is 48 words, so this is entered as the Size in Elements. The Local ControlNet Node is set to the MAC id of the 7500 PLS. In this example, the 7500 PLS has a MAC id of 5.

When the ladder logic program runs, an unscheduled message will be sent to the 7500 PLS containing the data that is programmed into integer file N13.



## Appendix A Ordering Information

### Part Numbering

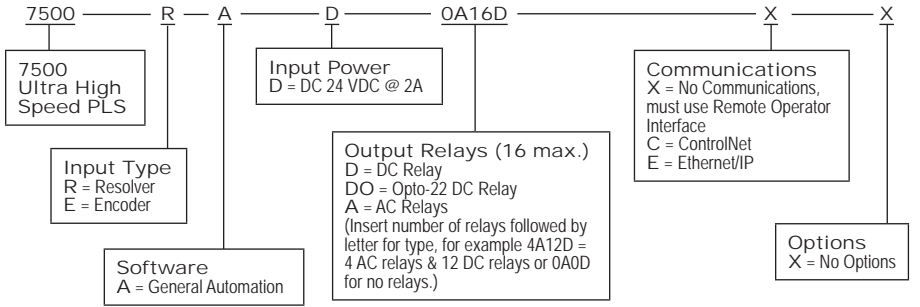

Resolvers	
Part Number	Description
1986A1XRX	Industrial Duty Foot Mount Resolver
1986F1XRX	Industrial Duty Block Mount Resolver
Many other models available. See Series 1986 Resolver catalog, part number Z4.	

Resolver Cables	
Part Number	Description
SD0534300L15	Resolver Cable Straight Connector 15 Ft.
SD0534400L15	Resolver Cable Right Angle Connector 15 Ft.
Cable length in feet is required at the end of the part number. Maximum cable length is 1,000 Ft.	

## Appendix B Troubleshooting

### Resolver Faults

The resolver's coil receives an AC voltage from the 7500 UHS. The rotor coil then feeds the stator coils, which gives a ratio metric feedback used to calculate position. WORD 10 contains the resolver fault data. A zero (0) indicates no resolver fault while one (1) will appear if a fault is detected.

1. Confirm resolver wire connections are secure and properly connected. See Figures in Chapter 3 for wiring details.
2. With a digital voltmeter set to AC, measure the voltage across the pins 5 (black of red) and 6 (red) on the position input connector. The voltage level should be between 3.6 and 5.0 VAC. If the voltage is present and is between 3.6 and 5.0 VAC continue to step 5. If the voltage is not present, see Chapter 3 Master/Slave Connections for correct dipswitch settings. If dipswitches are set correctly, and there still is no voltage continue to next step.
3. Remove the red and black of red wires from their terminal strip. With the voltmeter still set to AC, check the voltage across the terminals that the red and black of red wires were previously connected to. If no voltage is present, the resolver drive circuit has been damaged. Contact the factory for further assistance. However, if the voltage is present, continue on to the next step.
4. Set the digital voltmeter to resistance (ohms). With the red and black of red wires still removed from their terminals, check the resistance across the red and black wires. Normal readings will be between 15 - 50 ohms. If the reading is low, check the resolver cable for shorts. Remove the connector at the resolver end and check for a low resistance between the red and black of red wires. For pin out detail, see Figure 2-3. If the resolver cable check proves to be correct yet a low resistance is seen when connected to a resolver, it is likely that the resolver rotor coil has been shorted. Contact the factory for replacement of the resolver.
5. If the voltage in step 2 is present and is between the stated values, the 7500 UHS resolver drive circuitry is working properly. Next, with a digital voltmeter set to AC, check the voltages across the white (pin 4) and black of white (pin 3) on the position input connector. The voltage level should be between 0 and 5.0 VAC, depending on the resolver's position. Slowly rotate the resolver while monitoring the voltage levels. Within one revolution of the resolver, the voltage should make a cycle from approximately 0 to 5.0 VAC. If the voltage levels are present and are between the stated voltages continue to step 7. If no voltage is present continue to next step.
6. Remove the white and black of white wires from their terminal strip. With the digital voltmeter set to resistance (ohms) check the resistance between the white and black of white wires. Normal readings will be between 50 - 120 ohms. If the reading is low or infinite, check the resolver cable for open/shorts. Remove the connector at the resolver end and check for open/

shorts between the white and black of white wires. For pin out detail, see Figure 2-3. If the resolver cable check proves to be correct yet a low or infinite resistance is seen when connected to a resolver, it is likely that the resolver stator is open or shorted. Contact the factory for replacement of the resolver.

7. With a digital voltmeter set to AC, check the voltages across the green (pin 2) and black of green (pin 1) on the position input connector. The voltage level should be between 0 and 5.0 VAC, depending on the resolver's position. Slowly rotate the resolver while monitoring the voltage levels. Within one revolution of the resolver, the voltage should make a cycle from approximately 0 to 5.0 VAC. If the voltage levels are present and are between the stated voltages contact the factory for further assistance. If no voltage is present continue to the next step.

8. Remove the green and black of green wires from their terminal strip. With the digital voltmeter set to resistance (ohms) check the resistance between the green and black of green wires. Normal readings will be between 50 - 120 ohms. If the reading is low or infinite, check the resolver cable for open/shorts. Remove the connector at the resolver end and check for open/shorts between the green and black of green wires. For pin out detail, see Figure 2-3. If the resolver cable check proves to be correct yet a low or infinite resistance is seen when connected to a resolver, it is likely that the resolver stator is open or shorted. Contact the factory for replacement of the resolver.



## Appendix C Specifications

Specifications	
Outputs	32 Total
Ultra High Speed Outputs	16 Hard Outputs @ 5 microseconds update
Soft Outputs	16 Software Outputs @ 500 microseconds update and transmitted @ NUT (Network Update Time)
DC Relay	Output relay type G4ODC5 5-60 VDC, 3 amp max. load 1mA leakage current @ 60 VDC 50 microsecond turn ON and turn OFF time
AC Relay	Output relay type G4OAC5A 24-280 VAC, 3 amp max. load 1.25mA leakage current @ 120 VAC 2.5mA leakage current @ 240 VAC 8.3 millisecond turn ON and turn OFF time, one-half cycle maximum. Relay turns on at zero volt crossing of the AC sine wave.
Inputs	16 Total
Hardware Inputs	8 High Speed Hardware Inputs, interrupt driven, 10 microseconds typical, 500 microseconds worst case. 8 Isolated Inputs 10-30 VDC, Sourcing Device ON @ >1.5mA @ 10 V, >4.0mA @ 30 V
Software Inputs	8 Software Inputs @ NUT (Network Update Time)
I/O Groups	8 Total, Each group has programmable scale factor, offset, position and speed compensation
Input Configurations	10 types, including Reset to Preset, Output Enable, Remote Setpoint Tuning, and Output Forcing modes
Other Features	Adhesive applicator Add-On Test feature, Input Capture
Input Channels	1
Input Types	Resolver, 14-Bits (1 part in 16,384) Quadrature Encoder, 14-Bits (1 part in 16,384) +5 VDC @ 0.2A encoder power supply
Local Communications	Aux. RS485, consult factory for protocol
Network Communications	ControlNet, Others available, consult factory
Mounting	DIN rail or panel mount
Environmental Enclosure	IP50
Environmental Temperature	Operating 32-131°F (0-55°C), Storage 0-150°F (-17-65°C)
Input Voltage Required	10-30 VDC
Power Consumption	10 watts max., 7.5 watts typical
Fault Check Output Relay	8A @ 250 VAC, 8A @ 30 VDC,
Resolver Cable Length	1000 ft max.
Max. Speed	2048 RPM (encoder speed may vary)
RPM Calculation	14.65 milliseconds
Total Setpoints	8 Setpoint pair per output channel



Other Products



- GEMCO**
- LINEAR DISPLACEMENT TRANSDUCERS
- PLC INTERFACE PRODUCTS
- ROTARY POSITION PRODUCTS
- PROGRAMMABLE LIMIT SWITCHES
- EXTREME DUTY CABLE REEL PRODUCTS
- ROTARY LIMIT SWITCHES
- RESOLVERS
- MILL DUTY ENCLOSURES
- ULTRA HIGH SPEED PLS
- SAFETY PRODUCTS



Copyright 2007 by AMETEK AUTOMATION & PROCESS TECHNOLOGIES.  
All Rights Reserved. Made in the USA.



1080 N. Crooks Road, Clawson, MI 48017-1097  
Phone 248-435-0700 Toll Free 800-635-0289  
Fax 248-435-8120 [www.ametekapt.com](http://www.ametekapt.com)

7500.M3R  
4/08.Z186